

Electronic Engine Starter

EES6000

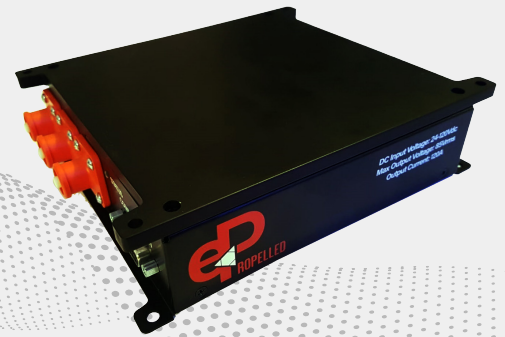

Key Features



Input and output undervoltage warning and 'pending shutdown' warning



Input and output short circuit protection



Over temperature warning and 'pending shutdown' warning

Fly Higher. Fly Longer. Fly Smarter.

Unmanned aerial vehicle (UAV) electronics continue to evolve as mission profiles become more demanding. System power designers are being challenged to provide more innovative power supply systems to improve efficiency, ensure reliability, reduce weight, minimize heat dissipation, and lower overall cost. New levels of energy and system-level efficiencies are also required to meet tomorrow's aviation needs.

ePropelled electronic engine starter (EES) module powers the starter generator during the engine start sequence and can be triggered digitally via the controller area network (CAN) interface or physically, through the pins on the interface connector. The EES module is intended to be sold with ePropelled starter generator SG3000 and the intelligent power system (iPS) module.

The iPS provides steady regulated DC power for onboard avionics, servo, and payload requirements. The smart iPS and EES also provide a wide array of real-time performance and operational data for a range of useful applications and analytics. The EES3000 monitors input and output voltage as well as current levels and collects and reports the data via the CAN interface. Aircraft and power system designers can create custom applications via our open application programming interface (API) and thresholds can be set for alerts and alarms based on specific uses and mission profiles.



EES6000 SPECIFICATIONS

Parameter	INPUT		
	Min	Max	Notes
Input voltage range*	65 V	120 V	DC (96 V default)
Input current range	0 A	110 A	-
Maximum total input power	10200 W		At 50°C Ambient [122°F]
Start duration	1 s	10 s	-
Start trigger	CAN or Digital		Through external CAN command
Parameter	OUTPUT		
	Min	Max	Notes
Output voltage range	0	0.577 *Vin	Peak line-neutral, SVM
Output current range	0	250 A	Peak
Total power	10000 W		DC at 50°C ambient [122°F]
Maximum RPM	4000 RPM		Depends on machine design
Parameter	MECHANICAL		
	Notes		
Dimensions	8.524" x 7.48" x 2.013" [216.5 mm x 190 mm x 51.13 mm]		
Weight (approximate)	15 pounds (6.8 kg) with a heat sink, 7 (3.17 kg) pounds without a heat sink		
Cooling	Natural		
Ambient operating temperature	-32°C to 50°C at 10 kW [-26°F to 122°F]		
Storage temperature	-40°C to 85°C [-40°F to 185°F]		
Ingress protection	IP20		

*Note: Depending on the characteristics of the engine, the effective engine starter voltage range may be in a narrower range than specified. This value is only provided as an indication of the range possible and will be dependent on the specific internal combustion engine (ICE) the customer has specified.

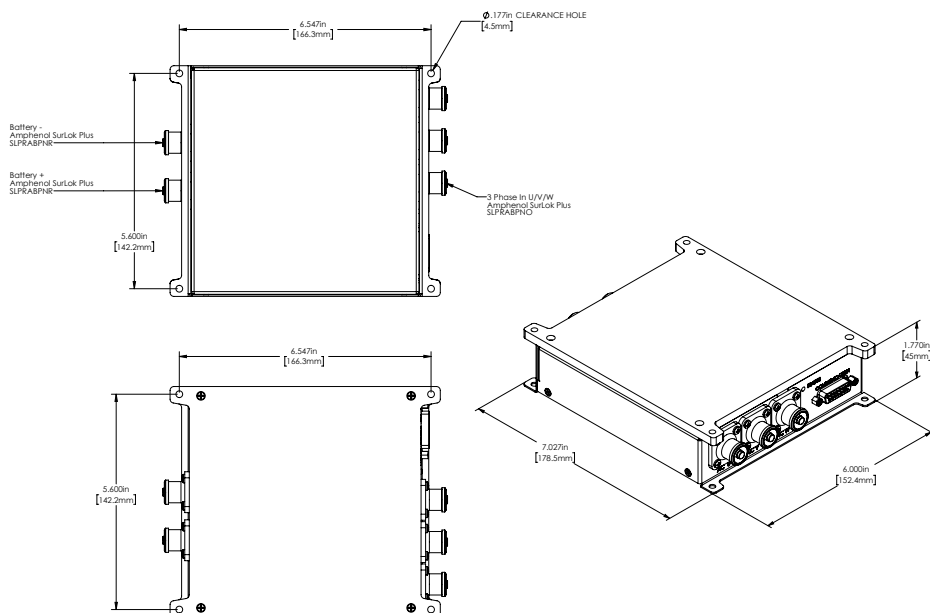

Derating with increased altitude

The derating factor for altitude is based on the loss of dielectric strength of the air as the density decrease with the altitude. The diagram below shows how the cooling efficiency changes with high altitude and ambient temperatures.

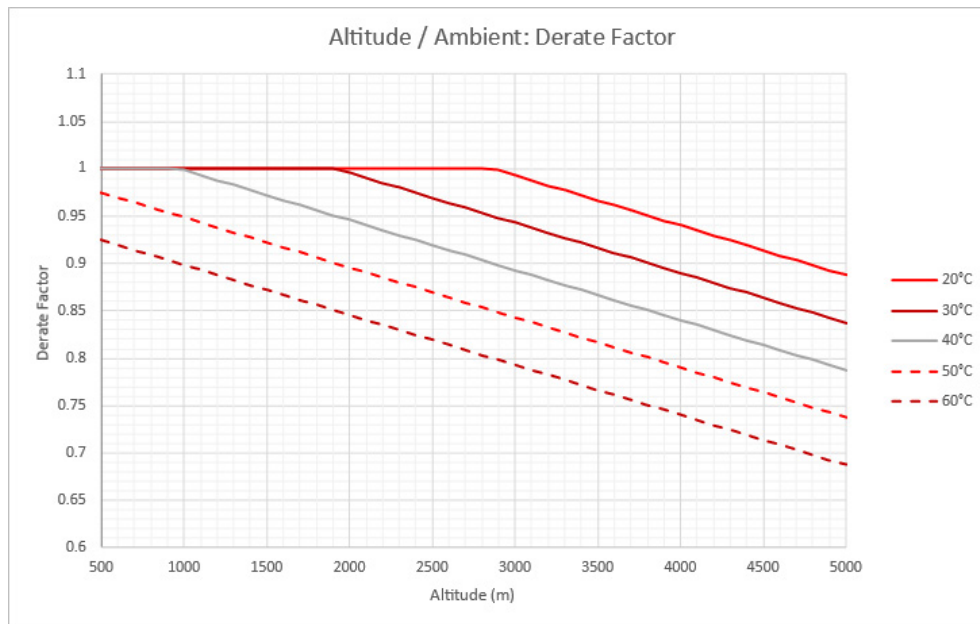

EES6000 PINOUT

Connector Type	Pin	Name	Description
Wurth 7460719	1	Phase U	3-phase output
Wurth 7460719	1	Phase V	3-phase output
Wurth 7460719	1	Phase W	3-phase output
Wurth 7461383	1	VDC+	DC input power for starting
Wurth 7461383	1	VDC -	DC input power for starting
Amphenol ICD15S13E4GX00LF	1	CAN2 LOW	-
	2	START	-
	3	3V3	-
	4	GND	-
	5	CAN1 HIGH	-
	6	CAN2 HIGH	-
	7	BOOT MODE SELECT	-
	8	SCI RX	-
	9	SCI TX	-
	10	CAN1 LOW	-
	11	JTAG TMS	-
	12	JTAG TCK	-
	13	JTAG TDO	-
	14	JTAG TDI	-
	15	PWM INPUT	-
RS PRO: 70643748	16/shell	GND	-
	1	K+	-
	2	-	-

Warnings and Labels



Assembled in USA

Errors and omissions excepted. All specifications subject to change without notice. For more information, including ordering product, please contact us at info@ePropelled.com.



ePropelled © 2021. ePropelled designs intelligent motors, motor controllers, generators, and power management systems. Our technology helps reduce energy consumption and improve system efficiency at a lower cost in the aerospace, manned and unmanned aerial vehicles, electric vehicles, and pump markets. We are a leader in magnetics engineering, and our patented technology innovations are used in the air, on the road, and on water, defining the future of electric propulsion.