



**ZENWAVE**

**ZA-18**

# **Massage Chair**

**User 's Manual**



[Http://www.zenawakening.com/](http://www.zenawakening.com/)



Galaxy Home Design  
7813 East Admiral Place  
Tulsa, OK 74115  
Phone number 918-835-1166

Please read SAFETY INSTRUCTIONS carefully before using the chair.

**ZENWAVE**  
**ZA-18**  
**Massage Chair**  
**Function Introduction**

1. With intelligent soft 3D massage in back, it can make the massage on neck, shoulder and waist parts more gentle, comfortable and suitable; adopting imitation of traditional Chinese medicine massage methods, let you enjoy the massage feeling like a real professional massagist, in addition, it can effect unique shoulder pressing function.
2. With acupuncture point tracking detecting function. It can supply exact massage according to different people with different body height and shape.
3. Unique Chinese medicine heating therapy in seat, waist and leg parts, promote blood circulation and relieve the pain of the body.
4. Combined with human body engineering research and development of super long I-shaped curve guide, make you fully enjoy intimate massage from head to leg, achieve the result of rapidly alleviate the pressure of the spine.
5. One-button press to perform zero gravity lie down function. It can effectively alleviate the pressure on spine and joints, allowing you to experience the real zero gravity.
6. The forward sliding function of 10cm from the wall. The backrest and seat frame move together, that can take full advantage of space, the design is full of humanization and will give you perfect feeling.
7. With advanced wireless Bluetooth technology, mobile phone connect with massage chair, to answer and end calls, Bluetooth music is available too, it can play mobile phone or tablet music.
8. The foot parts with full scrapping function, with rollers in feet, combination with gentle air bag force to stimulate the soles.
9. Leg parts equipped with multiple airbags, perform pulse air pressure massage on legs, to promote blood circulation, and restore the vitality.
10. Air pressure squeezing massage on your arms, which can promote blood circulation of blood capillary.
11. Multiple group of airbags in waist and seat, which can wrap up waist, buttock and thigh, realizing alternative air squeezing massage on different parts, eliminating tiredness quickly.
12. The legrest and foot parts can be adjusted to any angle that you needed, It can extended and retracted within the range of 15cm, suitable for different people to use.
13. Air bag massage on head, it can relieve brain fatigue, relieve body and mind pressure.
14. High resolution colorful LCD controller, it can show the massage parts, methods and status all the same time.

- ★ 1.Thank you for choosing this Massage Chair ZENWAVE ZA-18 Massage Chair.
- 2.Please read this manual carefully before using the massage chair.
- 3.Please keep this manual in a safe place for further reference.
- 4.Please pay attention to SAFETY INSTRUCTIONS.

★ Note: We reserve the right for design modification. It is subject to change without notice. The pictures in this manual are only for reference. Please refer to the actual product.



**Content**

<b>Preparation</b>	Safety instructions ..... 1
	External structure parts ..... 5
	Internal structure parts ..... 6
	Mechanical components diagram ..... 7
	Mechanical components list ..... 8
<b>Installation</b>	Installation ..... 9
<b>Massage Operation</b>	The adjustment before massage ..... 13
	Manual control ..... 15
	Operation instruction &function illustration ..... 19
	After massage ..... 21
<b>Maintenance</b>	Clean and maintenance ..... 22
<b>Others</b>	Malfunction guide ..... 23
	Technical data ..... 24





Please keep this manual in a safe place for future reference.

- ★ Please read this manual carefully to make sure the installation and operation of the massage chair is correct.
- ★ “Safety Instructions” is provided in both Warning and Caution for important safety information.

Both Warning and Caution are important safety caution, please pay more attention.

 <b>Warning</b>	This sign indicates warning of causing possible death or hurt to body.
 <b>Caution</b>	This sign indicates caution of causing possible hurt or damage to things.



### Symbol meaning

	This sign indicates forbidden behavior.		This sign indicates self disassembly is forbidden.
	This sign indicates must follow instruction to operate.		This sign indicates correct operation of cable.

- ★ The following should be kept for any further references.



## Warning

	<ul style="list-style-type: none"> <li>● Osteoporosis patient.</li> <li>● People with heart disease including embedded pacemaker or other medical electronic device inside the body.</li> <li>● For pregnant women or people not healthy, please consult doctor before use.</li> <li>● Patients with a high fever forbid to use this machine.</li> <li>● Perceptual disabilities patients forbid to use this machine.</li> <li>● People over 80 years old forbid to use this machine.</li> <li>● Kids and the drunk people are not allowed to use the chair.</li> <li>● Please don't sleep in the chair.</li> <li>● Don't use the chair when your body is wet.</li> </ul>	People who are not suitable to use the chair
	<ul style="list-style-type: none"> <li>● Make sure there are no kids or pets or other objects around (under, behind or in front of) the chair at the moment of backrest, leg-rest up/down or leg-rest retraction/extension from reclining position.</li> <li>● During operation, if you have body abnormal, please stop the operation and go to consult your physician.</li> <li>● Please do not take strong massage on the head.</li> <li>● Do not massage belly or knees, be careful when massage neck.</li> <li>● Children or pets are not allowed to play on the chair especially during massage. Standing or sitting on the back or armrest is not allowed either.</li> <li>● Those who are not sensitive to the heat or allergic to the heat must be careful when using it, or do not use.</li> </ul>	Accident/injury
	<ul style="list-style-type: none"> <li>● Insert the plug of the chair into correct and suitable power socket. Make sure the plug is completely inserted into the socket to reduce short circuit or fire risk.</li> <li>● Unplug the power when not in use, stop all massage functions and turn off on/off key before unplugging.</li> </ul>	Fire and electric shock
	<ul style="list-style-type: none"> <li>● It is prohibited to use the massage chair while any items covered the massage chair ventilation holes.</li> <li>● Massage cushions of the chair are not allowed to fold for storage.</li> <li>● The machine is forbidden for no-load running for a long time.</li> </ul>	Accident
	<ul style="list-style-type: none"> <li>● Power cord, plug, socket can't be used in broken or loose contact condition.</li> <li>● Don't use other electric power except rated voltage in case of fire, electric shock or any breakdown.</li> <li>● Any broken, re-process, knotted, twisted power cord or pressed under heavy cargo is not allowed to use.</li> </ul>	Fire and electric shock
	<ul style="list-style-type: none"> <li>● If the chair works dysfunctional, or is broken, splashed with water or falls into water, please have it repaired by professional repairman or send the chair to assigned service agent. Self-modification, disassembly or maintenance is forbidden.</li> <li>● If power cord or plug is damaged, please don't replace it yourself, please contact us or appointed dealer for replacement.</li> <li>● To avoid electric shock or body hurt, please don't open or disassemble any part of the chair, there is not any attached part of the chair for maintenance by customers.</li> <li>● Check leather or cloth material on the back and other areas is broken or not. If broken, even though it is small, please stop using the chair, unplug the power and have it repaired</li> </ul>	Disassembly and maintenance

**Caution**

	<ul style="list-style-type: none"> <li>● Please operate the chair in a flat or level place</li> </ul>	To avoid sudden falling.
	<ul style="list-style-type: none"> <li>● Position the chair 10cm from the wall to allow for sufficient space to recline up and down.</li> </ul>	To make sure the back lying.
	<ul style="list-style-type: none"> <li>● The maximum suggested operating time is 20mins. 5mins for each position beginning with the slight- step massage. Along continuous massage in the same position may cause uncomfortable feeling.</li> </ul>	Too long time massage is bad for your body.
	<ul style="list-style-type: none"> <li>● Before sitting on the chair to avoid injury please inspect everything to confirm that the massage heads are in the correct position.</li> </ul>	To avoid accidental injury.
	<ul style="list-style-type: none"> <li>● Remote control should be put in the pocket or on the bracket. Do not put the remote control anywhere casually in case of remote control damage.</li> </ul>	
	<ul style="list-style-type: none"> <li>● Please make sure that the power switch is at the "OFF" position before inserting the plug into the socket.</li> </ul>	To avoid the accident when turn on the power.
	<ul style="list-style-type: none"> <li>● Turn off all controls before removing plug from outlet.</li> </ul>	To reduce short circuits and any fire hazard.
	<ul style="list-style-type: none"> <li>● Make sure the plug completely insert into the socket.</li> </ul>	To avoid electric shock in any leakage or breakdown.
<ul style="list-style-type: none"> <li>● Checking whether any damage on wire, make sure no water or rubbish on wire.</li> <li>● Installing earth wire in correct way. The plug must be inserted into socket with earth connect, the earth connect couldn't be bend or cut off. </li> </ul>		
	<ul style="list-style-type: none"> <li>● Don't press with hands or step on the massage heads with feet.</li> <li>● Don't put hands between the working massage heads.</li> <li>● Don't put hands or feet in the gap of mechanical parts.</li> <li>● Don't drop or embed anything into the slot of massage chair.</li> <li>● Don't stand or sit or put anything on the backrest, armrest or leg-rest.</li> <li>● Don't stand on the chair during operation.</li> <li>● Don't move the chair during operation.</li> <li>● Don't pull out the plug or turn off the power during operation.</li> <li>● Don't put your hands or head between leg-rest or beneath.</li> <li>● Don't use the massage chair while wearing hair ornaments.</li> <li>● Don't put hard things in pocket when take buttocks and huckle massage.</li> <li>● Don't sit or press on the backrest when the chair is in reclining position.</li> <li>● Don't use at bare skin or were thin clothes, thin clothes may can achieve better massage effect, But it also may cause irritation to the skin or cryogenic burns.</li> </ul>	To avoid accidents or injury
	<ul style="list-style-type: none"> <li>● Keep the chair away from heat, wet, sharp things and corrosive, inflammable, explosive environment.</li> <li>● To use electric blanket or other heating products on the chair is forbidden.</li> <li>● Don't put in the space of dust serious or corrosive gas environment,</li> <li>● Don't put the chair in a small space places or use in the bad air circulation places.</li> </ul>	To avoid fade, discolor on upholstery or hardened, deteriorated on PU.
	<ul style="list-style-type: none"> <li>● Keep the chair away from stove or other heating products.</li> <li>● Don't put the chair directly under the sun or other high temperature places.</li> </ul>	
	<ul style="list-style-type: none"> <li>● Don't use the chair outdoor.</li> </ul>	

**Caution**

	<ul style="list-style-type: none"> <li>● Don't use or store the chair in the wet environment like nearing the swimming pool, or bathroom.</li> <li>● Keep the chair and remote control dry all the time.</li> </ul>	To avoid leakage or electric shock.
	<ul style="list-style-type: none"> <li>● Make sure to install the earth wire in correct way (Incorrect install way may cause electric shock. If you don't know how to install, please find a professional electrician)</li> <li>● Don't use plug adapter (If the enclosed plug doesn't match with socket, please don't change the plug by yourself and find a professional electrician to install a matched socket. )</li> </ul>	To avoid electric shock.
	<ul style="list-style-type: none"> <li>● Unplug the power before cleaning the chair.</li> <li>● Unplug the power after using the chair.</li> </ul>	To avoid electric shock or fire hazard.
	<ul style="list-style-type: none"> <li>● Unplug the power when any damage on the power.</li> <li>● Hold the plug to unplug the power but not try to pull the wire to unplug the power.</li> </ul>	
	<ul style="list-style-type: none"> <li>● Please turn off the power switch and unplug the power after massage.</li> </ul>	To avoid accidents
	<ul style="list-style-type: none"> <li>● Unplug the power immediately when electricity goes off.</li> </ul>	To avoid damage or accidents when power on again.

**Grounding instruction**

- ✦ ※The chair is equipped with a cord having an grounding conductor. The plug must be plugged into an appropriate socket that is properly installed and matched with the plug.

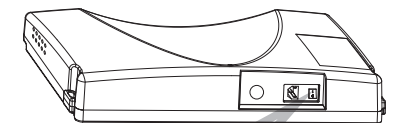
**Replace fuse**

- ✦ ※When the fuse is burned out, please turn off the switch and unplug the power. Opening the lid covered the fuse which is located in the switch box. Using a same size fuse to replace the old one, then cover the lid. Or you can find an electrician to replace the fuse.

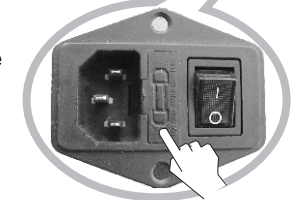

**Earth wire is not allowed to be in these places**

Gas pipe: probably cause explosion or fire.  
Phone wire and lightning rod: probably cause electric shock and fire when thundering.  
Water pipe: earth wire is useless where there are plastics



External structure

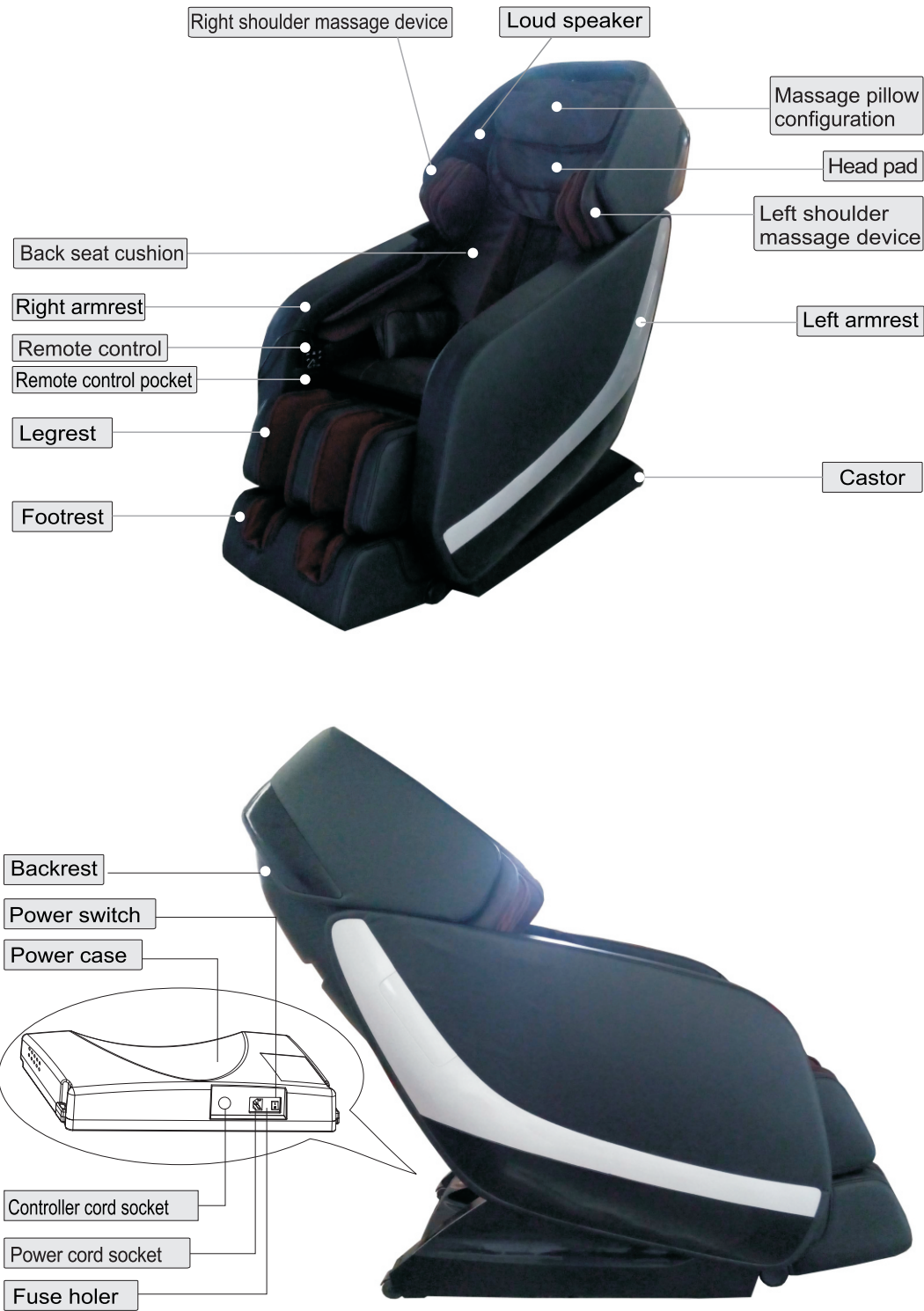

Preparation

Internal structure



Preparation

## Explosion Diagram

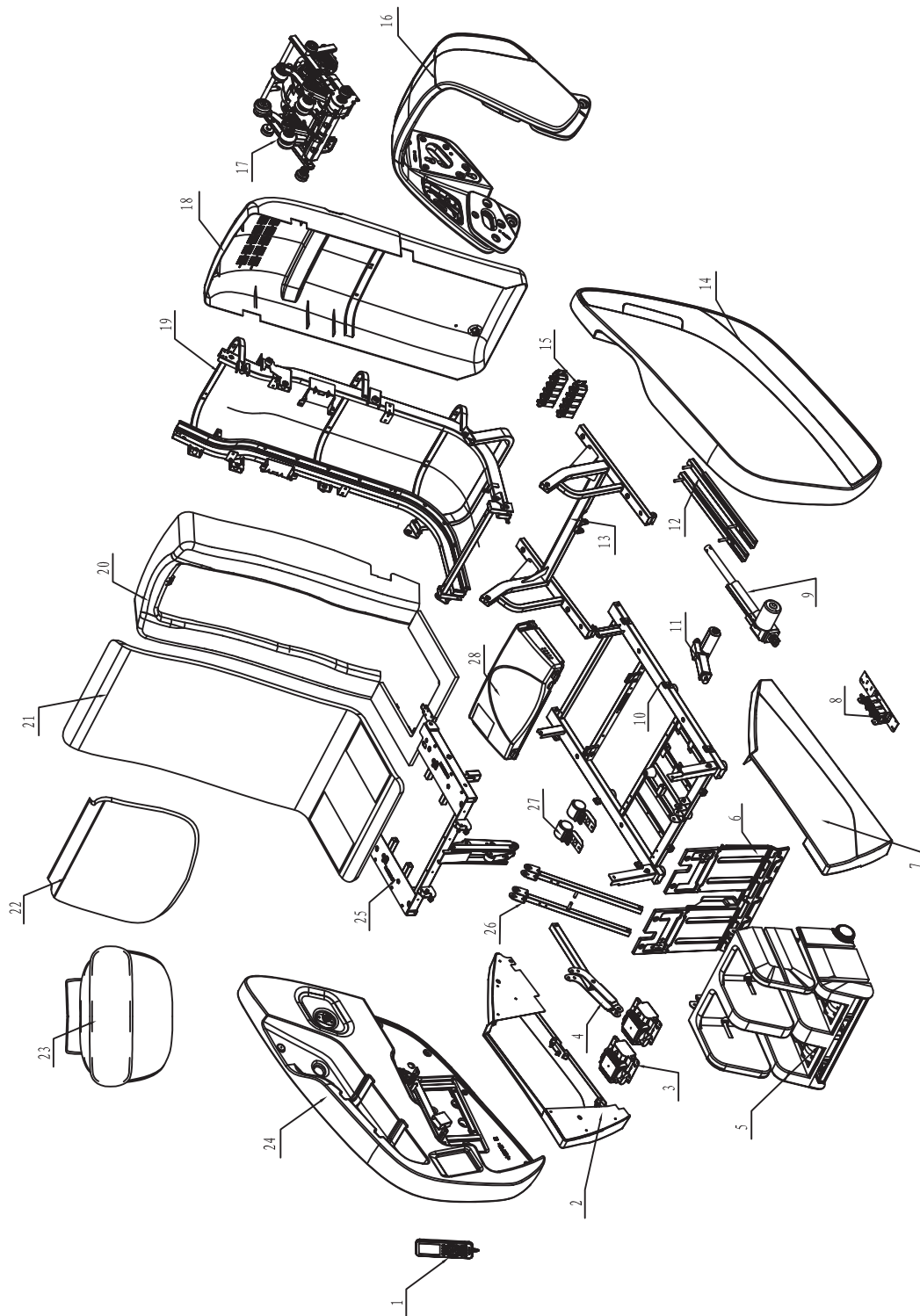

Preparation

## Mechanical components list

NO.	Name	Q' ty	NO.	Name	Q' ty
1	Remote control	1	22	Shoulder pads	1
2	Right side fender	1	23	Pillow	1
3	Air pump assembly	1	24	Right armrest assembly	1
4	connecting rod	1	25	Seat frame surface assembly	1
5	Legrest & footrest	1	26	Seat support bar	1
6	Front fender	1	27	Castor	2
7	Left side fender	1	28	Power case assembly	2
8	Electric magnetic valve	1			1
9	Backrest electric actuator	1			
10	Bottom seat frame assembly	1			
11	Footrest electric actuator	1			
12	Sliding rail	2			
13	Top seat frame assembly	1			
14	Left armrest assembly	1			
15	Electric magnetic valve	2			
16	Shoulder massage device	1			
17	Massage machine	1			
18	Back cover assembly	1			
19	Back frame assembly	1			
20	Backrest plastic front cover and seat plate assembly	1			
21	Back and seat cushion	1			

Preparation



## Installation (1)

## Step 1. How to move the chair

- ① Take out the back seat cushion box from the main carton box at first , and then two more people grasp left and right metal frame ,take the chair body from the main carton box .
- ② Take pillow, back cushion, power line, controller, etc. from the back & seat cushion box. (as the picture shows)



Head pad



Back seat cushion



Remote control



Electric power cable

One hand hold the metal seat frame and another hand catch the backrest , and then take the chair out of the box .



Massage chair main body

- ③ Take out the left and right armrest from the armrest carton box, Catch the two side of the armrest and take them out slowly. put the armrest on the table or ground in flat (pay attention to prevent scratches), Catch the left and right two sides from the front of armrest and take it slowly when installing the armrest.

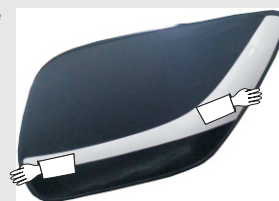

Left armrest



Right armrest

- ④ Take out the legrest device from the legrest carton box, catch the front and back two sides of the legrest and take them out.

Legrest device

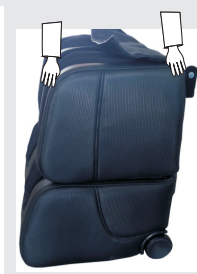

## Installation (2)

## Step 2. Massage chair position return

After take out the main chair body, ① Take out the power cord, insert one end of power cord to the socket on power box, another end insert into power socket. ② Turn on the power switch on power box, massage chair in power on status, backrest goes up and seat goes down. ③ After backrest return, turn off the switch, unplug the power plug. (Refer to step 7, after the assembly)



Massage chair position return state

## Step 3. How to assemble the legrest

Install the legrest to the main chair body , ① Unscrew the bolt from the hanger of legrest . ② Please insert three air tubes of the legs into the air taps of the main body, according to the color of plug, from left to right in turn to gray tube, brown tube, black tube. ③ Connect the power line plug to the socket tightly. ④ Lift up the legrest , put the axis into the hanger of main body, then put down the axis cover. ⑤ Screw on the bolt tightly.



## Installation (3)

## Step 4. How to assemble the left and right armrest

① Unscrew the M6 on the seat frame with cross screwdriver. ② Press the button on the fixed hole which inside the back of armrest, insert the fixed hole into the fixed bolt of side backrest. ③ Insert the square tube into the side piece of the seat frame. ④ Slightly move the armrest to make them front and back panel match bolt hole on the seat metal frame, screw M6 on the hole. ⑤ Open the zipper around the shoulder air bags, pull out the air bags, put the screw holes aligned between airbags and armrest, then put the screws inside the screw hole until fastened. Zip up at last. ⑥ Put the armrest tubes connect into the seat tubes.

⚠ Take care the air pipe when assembling and avoid squeezing.

✦ Disassemble the armrest: Zip up and move out the screws before disassembling the shoulder airbag. Disconnect the air tubes between the seat and armrest, unscrew the four screws on the seat, lift up the front of armrest, let the square tube of armrest move out from the plate of seat frame; then press the button on the fixed hole which at inside of back of the armrest and pull the end of armrest at same time, move the fixed hole away from the fixed bolt which on the side of backrest, then it will finish to disassemble the armrest.

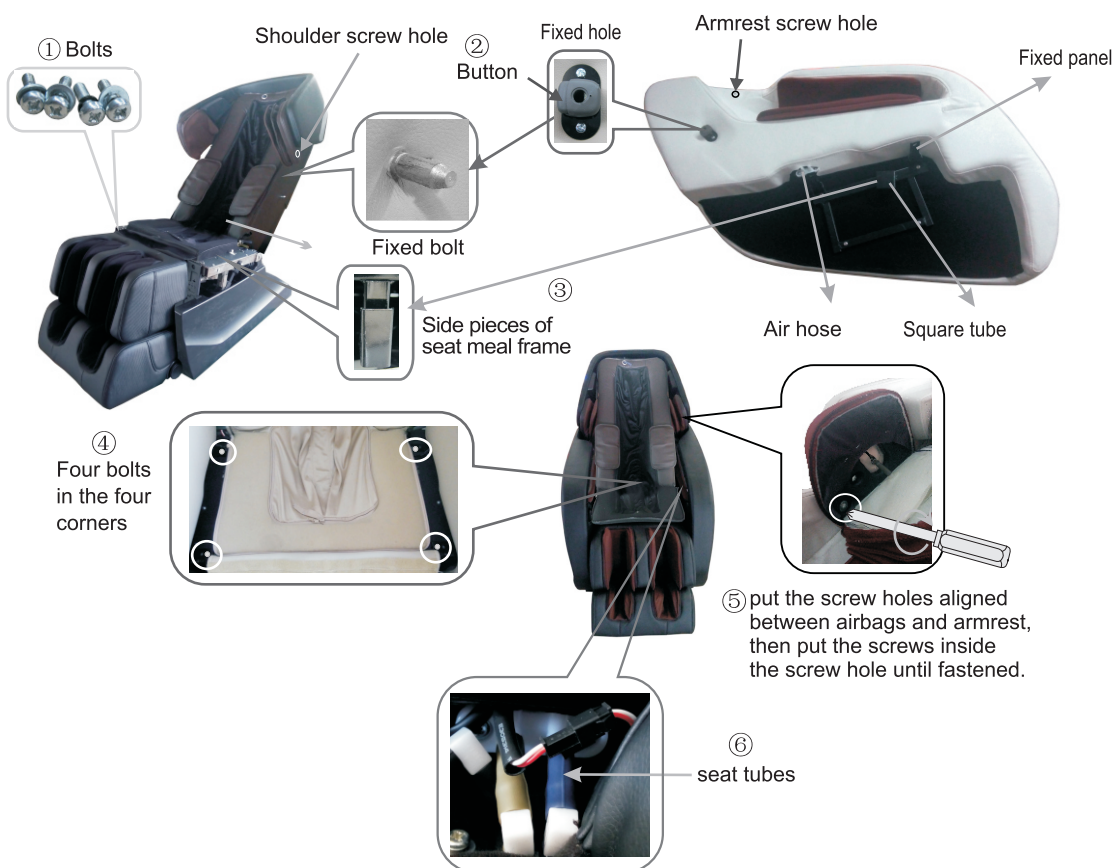

## Installation (4)

## Step 5. Connect the zipper or velcro

Put the back seat cushion, head pad onto the backrest and connect the two parts with zipper and velcro.

## ★ Warm tips

In order to get exact correct body test data for comfortable massage effect, when you sit on the chair, please make the bottom rim of the head pad flush with your ears before zipping the said two parts.

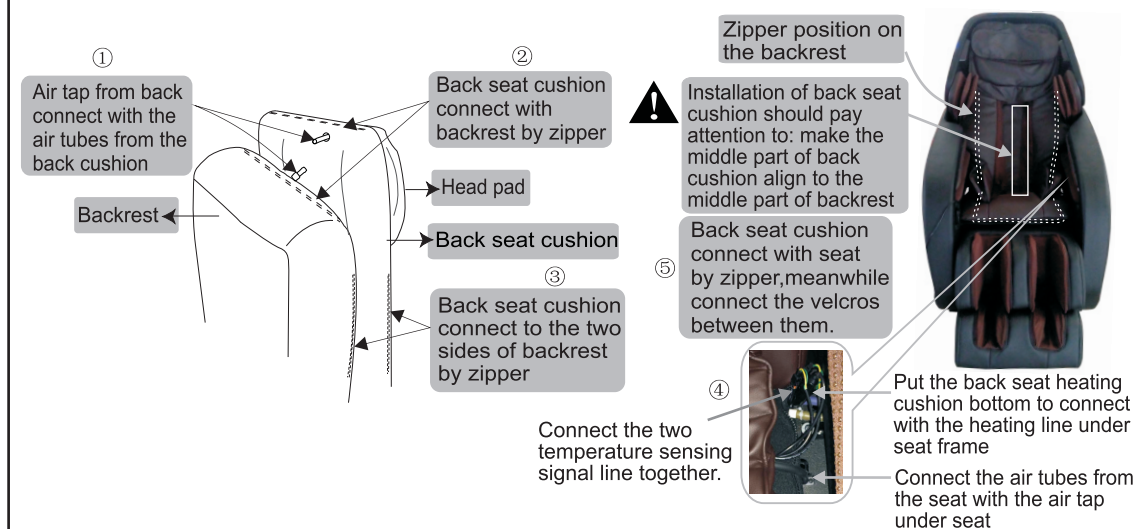
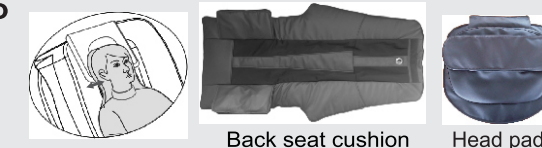

## Step 6. After the Assembly

After the assembly, please operate the chair in this order:

- ① Plug the cable line in the hole a on the power box as shown in the right picture.
  - Hole A connect with one end of cable line.
  - Hole b insert plug of the remote control.
- ② Insert the plug of cable line into the socket.
- ③ Switch on. (Switch on/off "O/I", press I down to turn it on.)
- ④ Enjoy the massage by using the remote control.

⚠ Make sure the switch is off before you insert the plug of cable line into the socket.

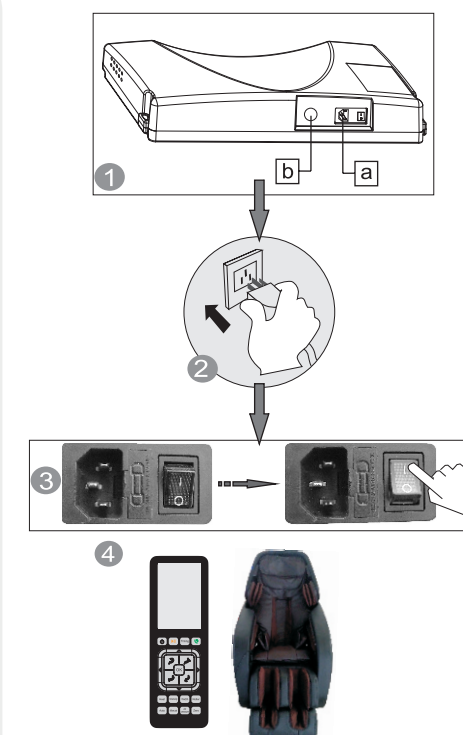



## Environment

 Caution

Don't use the chair in wet places like near swimming pool, bath room to avoid leakage or electric shock.



Don't use under sunlight or near stove or other heating place to avoid upholstery deteriorated.



Please use chair in flat place to avoid chair falling or noise or other unexpected trouble.

## ● Check places in front

Check the areas when back and leg extending, make sure no people, pets or other things around.



## ● Check power cable, plug

- (1) Clean the dust on plug on time. (using dry cloth).
- (2) No damage, re-do, bend, stretch, tie or press with heavy thing (especially can't be pressed by the chair) on power cable.



## Check environment

## ● Space size for using the chair

- At least 10cm from wall.



- At least 30cm in front of the leg:

## ● Check surroundings

When the backrest or legrest reclines or extends, please pay attention to:

- (1) Check any person or things in every direction.
- (2) Check the space size.



## How to move massage chair

 Caution

- ✦ Don't move chair when it's working in case of accidents or damage

## How to move

- ✦ Bind the cables and put them in the seat to avoid damage when moving.
- ✦ If you plump the chair, it may damage the inner parts of the chair.
- ✦ Don't use the castor if the floor is wooden or other easy damaged material. It will need 2 or more persons to lift the chair.
- ✦ Make sure the power is off and the plug doesn't touch the floor (It's better to let the chair in standing status to avoid the back crashing the floor)



## Normally

- 1 Lift up the legrest to make the gravity fall on the castor. Then push chair to destination and set it down.

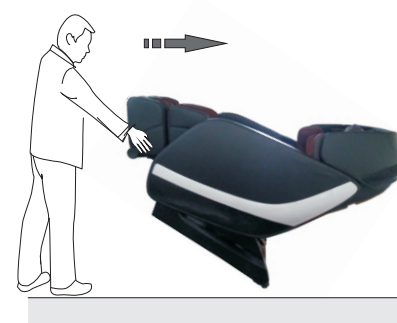

- ⚠ Please hold the footrest to move the chair as shown in the picture in case any scratches on the leatherette

## Adjustment before massage

## ● Before adjustment

- ✦ Please make sure the massage head in the seat part before sitting on the chair.
- ✦ To avoid injure caused by wrong position of the massage head.

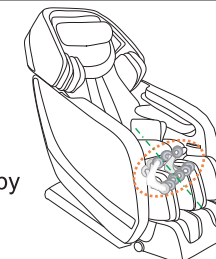

## ✦ Acupuncture point tracking detecting

When doing acupuncture point position detecting, if massage head can't detect the effective shoulder height position, the actual shoulder height position was default to the middle part of back.

**Right position:** Your back cling to the chair back, the head clings to the pillow.



The remote control gives "beep" sound after acupuncture point tracking detecting finished, when micro-adjustment is needed, just press up/down key on the remote control.

- ✦ Avoid for the massage head detecting your acupuncture point position not right, otherwise you won't get good massage.

## ● Kind suggestion



- When you feel the intensity isn't strong enough, take off the pillow or cushion.

- Because the chair is heavy, it may ruin your floor in long time setting. Please put a blanket or other soft things to protect your floor.



Manual control

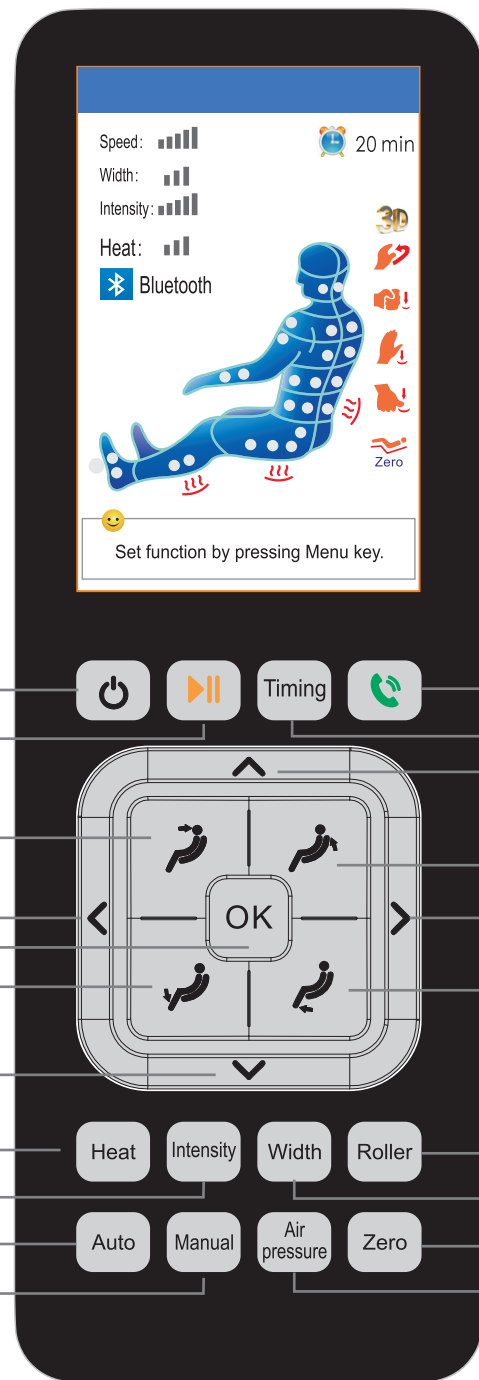

- Power On/Off
- Pause
- Timing
- Telephone call button
- Time button
- Upwards adjust button
- Backrest down
- Backrest up
- Towards left adjust button
- Towards right adjust button
- Confirm button
- Legrest down
- Legrest up
- Downward adjust button
- Heat button
- Foot roller button
- Intensity adjust button
- Width adjust button
- Auto button
- Zero-G button
- Manual button
- Air pressure button

Massage operation

- Power On/Off
- Pause
- Timing
- Telephone call button
- Backrest down
- Backrest up
- Legrest down
- Legrest up
- OK
- Navigation buttons (Up, Down, Left, Right)
- Heat
- Intensity
- Width
- Roller
- Auto
- Manual
- Air pressure
- Zero

1. Press power switch button under standby status, massage chair enters ON status. Press Menu or button to choose auto massage program or manual overall massage, then the massage machine starts shoulder height detection and starts to massage. In ON status, press power switch button, massage chair will turn off and return, massage machine automatic reset to the seat position, legrest stays in the lowest position, backrest stays in the highest position, the controller will turn off after the massage chair reset completely. Power off automatically if no selection in ON status after 30 minutes.
2. In ON status, press it to stop all the on-going massage immediately. If user wants to continue massage, press this key to recover massage. Auto power off after pause 30minutes.
3. In ON status, press this key to choose massage time. 5mins, 10mins, 15mins, 20mins, 25mins, 30mins in turn.
4. In ON status, when the mobile connect to massage chair via blue-tooth, the blue-tooth icon is bright. Press this key to answer or end the calls.
5. Keep pressing this button, backrest go down, legrest go up, release this button, backrest and legrest stop moving. When adjusting sitting position, it shows seat position adjusting... in controller screen.
6. Keep pressing this button, backrest goes up, legrest goes down, release it, backrest and legrest stop moving. Controller screen will show position adjusting... when adjusting the position of massage chair.
7. Keep pressing this button, legrest goes down, release it, legrest stop moving. Controller screen will show position adjusting... when adjusting the position of massage chair.
8. Keep pressing this button, legrest goes up, release it, legrest stop moving. Controller screen will show position adjusting... when adjusting the position of massage chair.
9. In ON status and under Menu mode, press it to confirm menu choice and enter next menu.
10. Navigation button has 4 buttons, they are Up, Down, Left and Right. In Menu interface, it is navigator button, user can press Up or Down to choose menu fast, and press Left or Right to enter previous or next menu. In Manual mode, Up and Down button can be used to adjust massage machine position in shoulder height detecting and fixed point massage. In Speed, Width, intensity setting: Left and Right button can be used to adjust the level.
11. In ON status, press this button to turn on/off the heating function . There are 7 heating position and program for your choice: waist- seat-legrest- waist &seat, seat & legrest- overall - stop, cyclic heating.
12. In ON status, press this button to adjust the massage speed, intensity and heating temperature. Select the desired mode, and relative screen display is glittering, and then you can press left/ right button to adjust the massage speed, intensity and heating temperature .
13. In ON status, press this button to adjust the massage width, and relative screen display is glittering on the controller, and then you can press left/right button to adjust the massage width.
14. In ON status, press this button to adjust foot roller massage speed : fast ,soft and stop .
15. In ON status, press this button to enter auto program menu.
16. In ON status, press this button to enter manual program menu.
17. In ON status, press this button to enter air massage menu
18. In ON or standby status, press this button, massage chair will go into zero-gravity position, press it again to return to default position.

Massage operation

LCD display graphic description

Main interface



After power is on, press on/off key, the buzzer gives a short ring, the LCD screen comes on without abnormal flash, the screen shows body massage area, massage method, time and current working status, etc., all of the information will be real-time updated.

- Massage function
- 3D — 3D
  - Kneading
  - Tapping
  - Knocking
  - Shiatsu
  - Zero gravity
  - Message time left

Message position

- Massage speed (5 shifts)
- Massage width (narrow, mid, wide)
- Air intensity (5 shifts)
- bluetooth display
- Heating

Massage operation

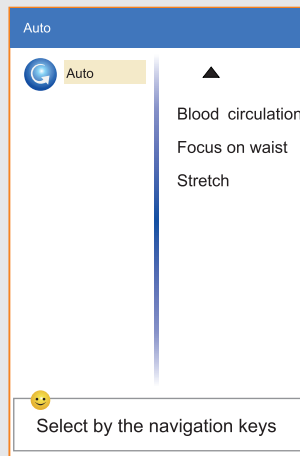
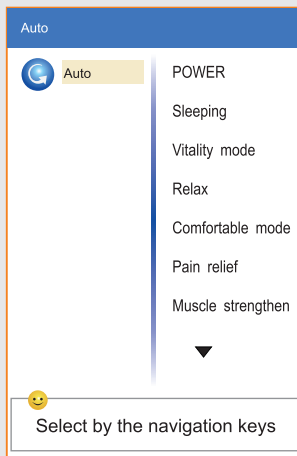

Auto massage: press "auto" in the main interface, the screen will turn to auto massage interface, there are 10 massage programs for option: power, sleeping, vitality mode, relax, comfortable mode, pain relief, muscle strengthen, blood circulation, focus on waist, stretch.

The above 10 programs have shoulder height detection function, as long as the shoulder height test is completed, choose any one of the 10 programs, shoulder height detection is not needed any more.

Back/seat angle can be adjusted automatically: During auto massage, the back/seat angle will be automatically changed (interval is a little long).

LCD display graphic description

Manual Massage: If the shoulder height detection doesn't complete, manual massage mode still has the shoulder detection function (except the fixed point). Once after shoulder detection completes, just select any massage method, no need to do shoulder height detection again.

1. 7 massage methods: shiatsu, kneading, tapping, knocking, shiatsu (rolling), mix 1(Knead+Tap) and mix 2(Knead+Knock).

2. 5 positions for choice:

Neck and Shoulder Mode: massage neck and shoulder

Shoulder and Back Mode: massage shoulder and back

Back and Waist Mode: massage back and waist

Waist and Seat Mode: massage waist and seat

Whole Body Mode: massage the whole body

During 3D Feel mode, only three positions are available, neck and shoulder mode, shoulder and back mode, back and waist mode.

3. Fixed Point

1. When select massage method, the default mode is whole body.
2. Select massage method before choosing the position or fixed point.
3. Select Manual mode, all air pressure massage shall turn off.

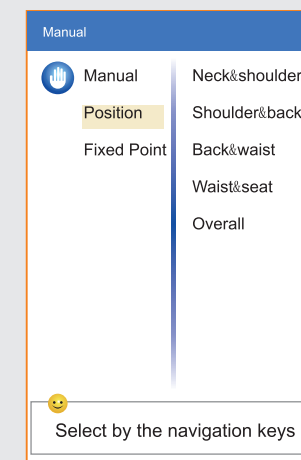
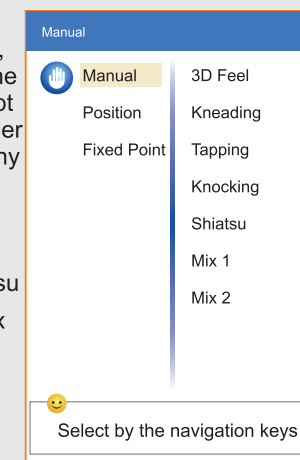

Massage operation

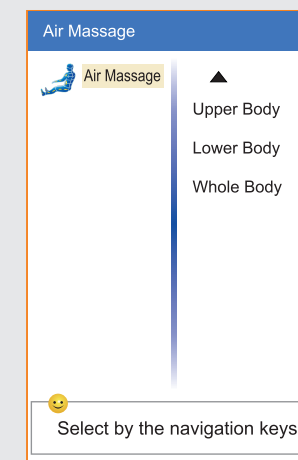
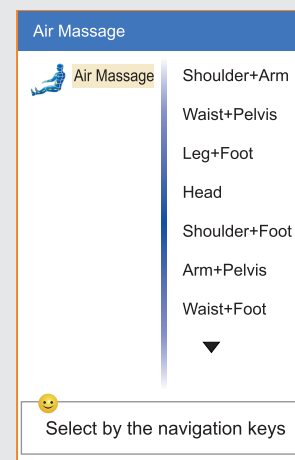

Air Massage: Ten air massage modes for you to choose, Shoulder+Arm, Waist+Pelvis, Leg+Foot, Head, Shoulder+Foot, Arm+Pelvis, Waist+Foot, Upper Body, Lower Body, Whole Body Mode. Once air massage is activated, the mechanical massage of the back massage machine shall stop.

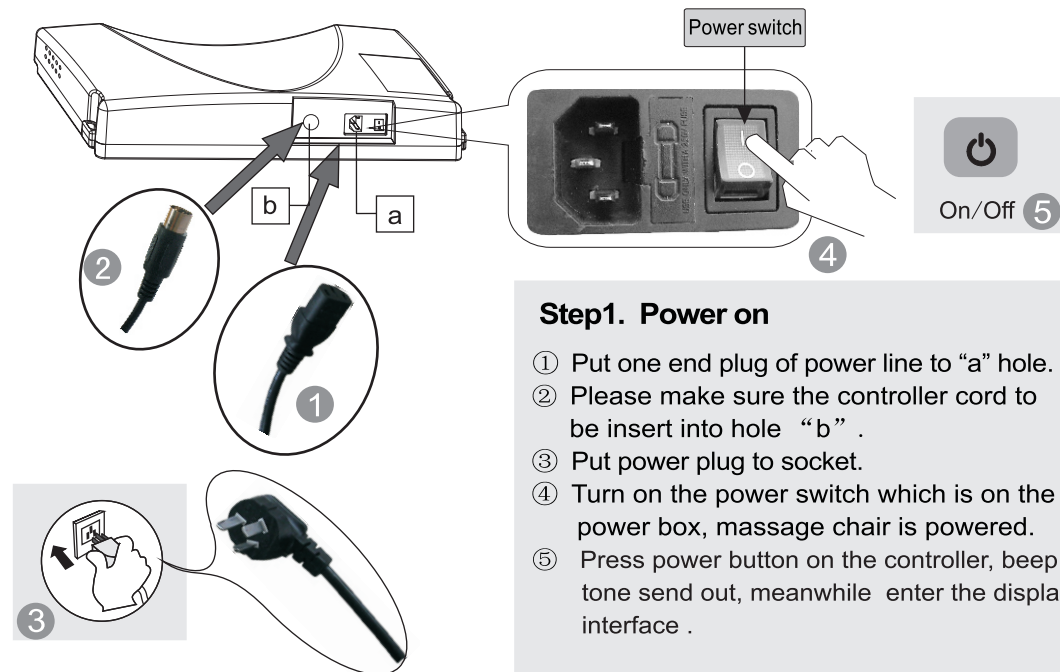

## ON/OFF

**Step1. Power on**

- ① Put one end plug of power line to "a" hole.
- ② Please make sure the controller cord to be insert into hole "b".
- ③ Put power plug to socket.
- ④ Turn on the power switch which is on the power box, massage chair is powered.
- ⑤ Press power button on the controller, beep tone send out, meanwhile enter the display interface.

**Step2. Massage**

- ① Operate according to controller operation instruction.
- ② When massage stop, massage machine return to the default position, meanwhile "Shutting down" displayed on the controller, controller off after 3-5 seconds.

**Step3. Turn off the power**

- ① When the chair is On, press On/Off button to turn off the massage chair and it will restore automatically.
- ② Turn off the power switch on the bottom of the back of chair after the rollers stay at storage position.
- ③ Unplug the power plug from the socket.

**Warning**

1. Before using, pull up the pillow, back cushion etc. to check if the PU material is broken, if there is damage, please stop using, unplug the chair, and ask for repairment.
2. Only plug to proper socket.

**Attention**

1. Before sitting down, make sure there is no things pinched between armrest, legrest, backrest and seat of the chair.
2. Make sure the chair is in returned position before using.
3. Do not stand on it when using the massage chair.

## Function Illustration

**● Legrest up and backrest down**

Press this button on controller, backrest go down and legrest go up. Release this button, backrest and legrest stop moving, the angle is locked in this position.

**● Legrest extend and retract**

Legrest can extend or retract within a range of 15CM.

**● Backrest up and Legrest down**

Press this button on controller, backrest go up and legrest go down. Release this button, backrest and legrest stop moving, the angle is locked in this position.

**● Arm massage**

Put arms between arm airbags before the embedded airbags filled with air. It will perform pinch massage techniques to arms and hands after airbags inflating.

**● Legrest Down**

Press this button on controller, legrest goes down. Release the button, legrest stops moving, the angle is locked in this position.

**● Shoulder massage**

Multilayer extrusion airbags is deployed on both sides of the shoulder. Achieve pressure shoulder stretch massage, relieve shoulder fatigue.

**● Legrest Up**

Press this button on controller, legrest goes up. Release the button, legrest stops moving, the angle is locked in this position.

**● Foot roller massage**

Footrest parts with roller massage and air pressure massage function. Through stimulating the foot reflex zones, and clear the body meridians, regulate and restore human organs function, improve the body resistance and immunity effectively.

**● Zero gravity**

Press the button "Zero", backrest go down and legrest raise up, the chair go into Zero gravity status automatically. Press the Button again, the backrest and legrest stop moving, and it will lock at this position. However to change the angles, we can keep comfortable massage status all the time.



1. Please make sure there is no people, no pets or any stuff within range for backrest to avoid unexpected hurt or property loss.
2. When adjusting the backrest, be careful the gap between the backrest and armrest.
3. When the legrest is moving, please do not stand on or leave from the seat, do not stop the legrest from moving in case of causing damage to the chair.
4. Please refer to control instruction for more details.



## Restoration of massage chair

- 1 Make sure there is no people or pet or anything within the range of backrest and legrest.



- 2 Make backrest and legrest restore to the normal position by controller. (or press ON/Off key to make backrest and legrest restore to the normal position)



- 3 After restoring, put the controller back into the pocket of the right armrest .



- 4 Put the pillow pad on to the right position.

- 5 Switch off the power.

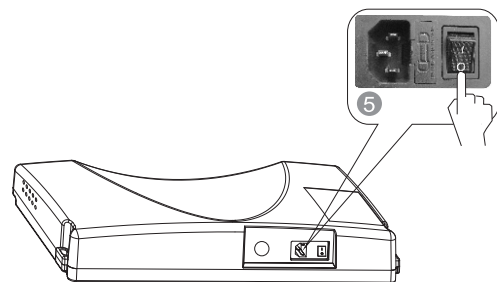

- 6 Unplug the electricity from the socket. (Attention: hold the right plug position)

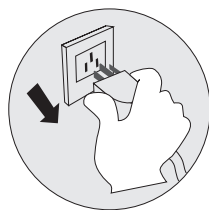

- 7 Clean the chair if necessary.



## Attention!

- After using, press ON/OFF to end all the massage method and wait for restoration.
- Make sure to cut the electricity to avoid any unexpected hurt to children or pets.
- After using, turn off the power, unplug the electricity. Avoid moisture, dirt and aging of insulation in case of causing damage.

## Synthetic leather

## ● General cleaning

Clean with tidy, soft and dry cloth slightly.



(Chemical or medical cleaning products are forbidden)



Forbidden



## ● If leather is dirty

- 1 Dip soft cloth into 3-5% neutral detergent solution, squeeze it then clean the stain on the surface gently.
- 2 Wash cloth, squeeze it and wipe with detergent.

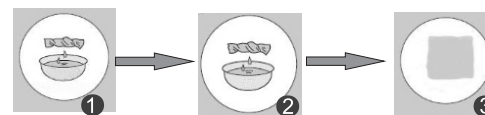

- 3 Clean it softly with dry cloth.
- 4 Allow to dry (air blower is prohibited)

## Cloth material

- 1 Dip cloth into weak neutral detergent, squeeze it and clean the material surface.

- (Diluent, gas, alcohol are prohibited)  
Brush the dirty parts with weak neutral detergent. (avoid excessive brushing)



Forbidden



- 2 Excessive cleaning may cause damage to cloth material.
- 3 Wipe with water-dipped but squeezed cloth.
- 4 Allow to dry.

## Plastic parts

- 1 Dip cloth into neutral detergent, squeeze it and clean.
- 2 Wipe with water-dipped but squeezed cloth.
- 3 Allow to dry.



## Clean the controller

- 1 Wipe with soft cloth after squeezing.
- 2 Allow to dry.  
Propellant, diluent or alcohol are prohibited.



Forbidden



Controller



## About cleaning

- Before cleaning, unplug the electricity, don't touch plug with wet hands.
- Make sure hands are dry when plugging to the socket.
- If failed to follow the mentioned instruction, user may get electric shock or burned.

## FAQ and Troubleshooting

Trouble	Possible reason	Troubleshooting
The massage chair can't work after power is on.	Check if the control is on or not.	Open control switch
	Not choose massage function	Choose massage function
	Check whether the plug and socket in poor contact.	Make sure plug and socket are connected.
	Wire or plug has damaged.	Please ask manufacturer or appointed or authorized maintenance man for checking and replacement.
	The fuse burned out.	Replace fuse of same specification.
	Something wrong with inner circuit	Please ask appointed or authorized maintenance man for checking and repairing.
There is beep sound inside the massager while working.	It is sound of air pump, motor and mechanical parts.	Normal sound, no need to pay attention to it.
Different height of the left roller and right roller.	Massage rollers work on shifts.	Normal, no need to pay attention to it.
Sound suddenly becomes much louder while working.	Check if it is due to long time working.	Turn off the power to have the massager rest for over half an hour before next turn working.
	Inner parts fretted away due to long time work. It's normal	Please ask appointed or authorized maintenance man for checking and repairing.
Massage function suddenly stops while working.	Suddenly power-down	Connect the electricity power again
	Setting time is up.	Turn off the power to have the massager rest for over half an hour before next turn working.
Neither the backrest nor the legrest can be lay down.	Check if there are any obstacles; the chair overloads; for the sake of safety, sometimes the massage machine may automatically stop working.	Remove the obstacles; turn off the power to have the massager rest for over half an hour before next turn working.
The chair can't return to its original position.	Excessive operation; setting time is up.	Please ask manufacturer or appointed or authorized maintenance man for checking and replacement.
Electric wire or plug give out heat	It may work overload	Turn off the power to have the massager rest for over half an hour before next round working.
	Other abnormal case	Stop using, and ask appointed maintenance man for help.



Note: If the troubles are not caused by above reasons, please turn off the power switch and cut off the power, then contact the manufacturer or service agent to repair your chair.

## Technical data

Name	Massage Chair	Power	200 W
Model	ZENWAVE ZA-18	NW/GW	Main body :78/102 kg Armrest : 15.5/22kg Legrest &footrest : 15/17.5kg
Input voltage	<input type="checkbox"/> AC120V, 60Hz <input type="checkbox"/> AC220V, 50/60Hz <input type="checkbox"/> AC240V, 50Hz	Packing size	Main body: 1510×790×1030 mm Armrest : 1245×410×655 mm Legrest &footrest :530 × 445 × 540 mm (L×W×H)
Safety design	Class I		