

Connect X200

CXG3.X200



Connect X200 for the cloud integration of Siemens Smart infrastructure as well as third-party systems

- 2-port Ethernet switch for LAN (incl. Daisy Chaining)
- 1-port Ethernet for WAN
- 2 EIA-485 interfaces
- USB interface for 4G dongles
- Operating voltage AC 24 V or DC 24 V
- Mounting on standard rails or on the wall
- Plug-in screw terminal blocks
- Multi-site management (depending on firmware)
- Remote operation & monitoring (depending on firmware)
- Alarm treatment (depending on firmware)
- Remote tool access, update and configuration via Siemens Cloud Services (depending on firmware)

Functions

Connect X200 provides two integration levels for connecting devices to the cloud: System integration (between the Connect X200 and the devices) and cloud integration (between the Connect X200 and the cloud).

A broad range of devices can be integrated on the system level (i.e. Desigo, FS20, third-party systems). Connect X200 supports various protocols (BACnet, Modbus,) and different media (Ethernet, serial EIA-485 bus).

The device supports Ethernet and 4G on the cloud level via the MQTT protocol.

The specific set of supported functions may vary according to the region (for example UL markets) and according to the connected system. Detailed information about the latest supported functions can be found in the release notes of the installed software.

Application

Connect X200 is a physical device that is the connecting point between the cloud and controlled/monitored devices, such as controllers, sensors, and actuators in the building.

The device integrates common BACnet/IP or Modbus/TCP devices and systems as well as Siemens fire system protocols.

It securely transmits data to the cloud over cable networks or over mobile networks (e.g. 4G: With a router). 4G USB Dongle support is available in addition (see "Accessories").

Type summary

Type	Order number	Description
CXG3.X200	S55842-Z131-A100	Connect X200

Equipment combinations

Accessories



The accessories listed below are tested but not sold by Siemens Smart Infrastructure.

Manufacturer	Type	Description
Siemens	6EP3332-6SB00-0AY0	Power supply DC 24 V / 2.5 A
Verizon	USB730L / MC730	4G USB Dongle
Huawei	E3372 / E3372h - 153	4G USB Dongle
Huawei	E3372 / E3372h - 320	4G USB Dongle
Alcatel	IK40V-2AALDE1	4G USB Dongle



Please confirm compatibility of the chosen 4G Dongle according to the infrastructure of your regional Internet Service Provider before choosing and ordering a specific device (i.e. compatibility of regional 4G frequency bands). Consult "4G Dongle Commissioning Guide" for further instructions and information.

Technical and mechanical design

The compact build can be mounted on standard rails or walls.

1	Plastic housing
2	LEDs for communication and status
3	Service button
4 a)	2-port Ethernet switch with 2 LEDs per port
4 b)	1-port Ethernet interface with 2 LEDs for WAN (Internet access)
5	Plug-in terminal blocks with screw terminals Power supply
6	USB interface for 4G dongles
7	Plug-in terminal blocks with screw terminals COM1 / COM2
8	DIP switches for bus termination and polarization (COM1 / COM2)
9	Slider for mounting on standard mounting rails
10	Eyelets for cable ties
11	Holes for wall mounting
12	Date / Series and Serial number

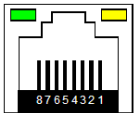
LED indicators

Activity	LED / Interface	Color	Activity	Function
	Ethernet 1...3	Green	Continuously ON Continuously OFF Flashing	Link active No connection Network traffic
		Yellow	Continuously ON Continuously OFF	Link 100 Mbps Link 10 Mbps
<ul style="list-style-type: none"> ■ RUN ■ COM1 TX ■ COM1 RX ■ APPS ■ COM2 TX ■ COM2 RX SVC 	RUN	Green	Continuously ON Continuously OFF Flashing	Device operational Device not operational Start-up or program halted
		Red	Continuously OFF Continuously ON Rapid flashing	OK HW or SW fault - power off and on the X200 Firmware or application missing/corrupted
		Blue	Continuously ON Continuously OFF Flashing	Connection to the cloud OK No connection to the cloud Onboarding to cloud not finished or device certificates not updated
	APPS	Green	Continuously OFF Continuously ON Flashing	No app(s) installed on the device Installed app(s) are properly working Installed app(s) are (re)starting
	SVC	Red	Continuously OFF Continuously ON	IP address not assigned to LAN port IP address assigned to LAN port
	COM1 / 2 TX	Yellow	Flashing	Communication
	COM1 / 2 RX	Yellow	Continuously OFF	No communication to subsystem

Activity	LED / Interface	Color	Activity	Function
 SVC	Service button		Long press, up to 20s (power off device first)	Factory reset All configuration data and installed apps are deleted If RUN LED is constantly green, factory reset was successful
			Short press	IP address 169.254.169.254 will be assigned to LAN port for the duration of 15 min.

Product documentation

Related documents such as the environmental declarations, CE declarations, etc., can be downloaded from the following Internet address:

<https://siemens.com/bt/download>

Notes

Safety

	⚠ CAUTION
	National safety regulations Failure to comply with national safety regulations may result in personal injury and property damage. <ul style="list-style-type: none"> Observe national provisions and comply with the appropriate safety regulations.

Mounting position and ambient temperature

The devices can be snapped onto standard rails or screwed onto a flat surface. Plug-in screw terminals connect power and interfaces (except for Ethernet).

Ambient temperature -5...50 °C (23...122 °F)	Ambient temperature -5...45 °C (23...113 °F)
<ul style="list-style-type: none"> Wall, horizontal <ul style="list-style-type: none"> From left to right From right to left 	<ul style="list-style-type: none"> Overhead Wall, vertically <ul style="list-style-type: none"> From top to bottom From bottom to top On a horizontal surface

	⚠ CAUTION
	Risk of overheating for failure to comply with ambient temperature Burning and damage to the device <ul style="list-style-type: none"> Ensure sufficient ventilation to comply with the permissible ambient temperature within the panel or installation box. The temperature must be at least 10 K (18° F) lower outside the installation box.

Installation

	⚠ WARNING
	<p>Electric shock</p> <p>Incorrect installation of the device may lead to electric shock injuries when touching the device!</p> <ul style="list-style-type: none"> • Install the device in a lockable cabinet or use terminal covers. • Do not install the device in locations where children are likely to be present. • Conductors with a cross-section of 0.5 mm² (AWG24) or greater shall comply with the requirements of IEC 60332-1-2 and IEC 60332-1-3 or IEC TS 60695-11-21.

Commissioning / service

	NOTICE
	<p>When using a 4G dongle</p> <p>Reboot the device after a 4G dongle has been connected. For details see 4G Dongle Setup (A6V12059208).</p>

Disposal

	<p>The device is considered an electronic device for disposal in accordance with European Directive and may not be disposed of as domestic waste.</p> <ul style="list-style-type: none"> • Use only designated channels for disposing the devices. • Comply with all local and currently applicable laws and regulations.
---	---

Technical data

Power supply

Operating voltage 24 V AC (24 V _~ , ⊥, ⚡)	AC 24 V -15 / +20 % (SELV / PELV) or AC 24 V Class 2 (US) 48...63 Hz
Operating voltage 24 V DC	DC 24 V -15 / +20 % (SELV / PELV) or DC 24 V Class 2 (US)
Functional ground (US) Functional earth ⚡	The terminal for the functional ground must be connected on the installation side with the building grounding system (PE).

Screw terminals for wire cross sections up to	Max. 2.5 mm ² (14 AWG)
Internal fusing	2.5 A irreversible / non-replaceable
External supply line fusing (EU)	Non-renewable fuse max. 10 A slow or circuit breaker max. 13 A Tripping characteristic B, C, D per EN 60898 or Power supply with current limitation of max. 10 A

Power consumption (for transformer planning)

Power consumption AC	16 VA
Power consumption DC	8 W

Function data

Hardware information	
Processor	NXP i.MX8 DualX
Storage	2 GB RAM 8 GB eMMC

Data backup in the event of power failure
Super cap to support real-time clock (7 days).

Interfaces

Ethernet interfaces	
Plug	3 x RJ45, shielded
Interface type	10Base-T / 100Base-TX, IEEE 802.3 compatible
Bit rate	10/100 Mbps, autosensing
Protocol	BACnet on UDP/IP and HTTPs on TCP/IP
Cabling, cable type	10 Mbps: Min. CAT3, shielded cable is recommended 100 Mbps: Min. CAT5, shielded cable is recommended
Cable length	Max. 100 m (330 ft)

Screw terminals, plug-in	
Cu-wire or Cu-strand with wire end sleeve	1 x 0.6 mm \emptyset to 2.5 mm ² (22 to 14 AWG) or 2 x 0.6 mm \emptyset to 1.0 mm ² (22 to 18 AWG)
Cu-strand without wire end sleeve	1 x 0.6 mm \emptyset to 2.5 mm ² (22 to 14 AWG) or 2 x 0.6 mm \emptyset to 1.5 mm ² (22 to 16 AWG)
Stripping length	6...7.5 mm (0.24...0.29 in)
Screwdriver	Slot screws, screwdriver size 1 with shaft \emptyset = 3 mm
Max. tightening torque	0.6 Nm (0.44 lb ft)

EIA-485 interfaces	
Interface type	EIA-485, electrically isolated
Baud rate	1200, 2400, 4800, 9600, 19200, 38400, 57600, 115200 (depending on the configuration)
Internal bus termination	120 Ohm, switchable with DIP switch
Internal bus polarization	270 Ohm pull-up/pull-down resistances, switchable with DIP switch
Cabling (in-house cabling only) Cable length	3-wire cable Max. 1000 m (3300 ft)
Protection	Short-circuit proof Protection against faulty wiring with AC 24 V and DC 24 V

USB interface (4G internet connection)	
Plug	Type A
Interface type	USB 2.0
Bit rate	480 Mbit
Max. load	500 mA
Max. cable length	5 m

Conformity

Ambient conditions and protection classification	
Classification as per EN 60730 Automatic action Control function Degree of pollution Overvoltage category	Type 1 Class A 2 III
Design	Suitable for use in protection class I or II systems
Degree of protection of housing to EN 60529 Front parts in DIN cut-out Terminal part	IP30 IP20
Climatic ambient conditions <ul style="list-style-type: none"> Storage / Transport (packaged for transport) as per IEC EN 60721-3-1 / IEC EN 60721-3-2 Operation as per IEC/EN 60721-3-3 	<ul style="list-style-type: none"> Class 1K22 / 2K12 Temperature -25...70 °C (-13...158 °F) Air humidity 5...95 % (non-condensing) Class 3K23 Temperature -5...50 °C (23...122 °F) (for details see chapter Mounting) Air humidity 5...95 % (non-condensing)
Mechanical ambient conditions <ul style="list-style-type: none"> Transport per IEC/EN 60721-3-2 Operation as per IEC/EN 60721-3-3 	<ul style="list-style-type: none"> Class 2M4 Class 3M11

Standards, directives and approvals	
Product standards	EN 60730-1 and EN 62368-1
Product family standard	EN 50491-x
Electromagnetic compatibility (EMC)	For residential, commercial, and industrial environments
EU conformity (CE)	See CE declaration ¹⁾
EAC compliance	Eurasian compliance
RCM conformity	See RCM declaration ¹⁾
UL/cUL approbation (US / Canada)	UL916; http://ul.com/database
CSA certification	C22.2, http://csagroup.org/services-industries/product-listing
Environmental compatibility ¹⁾	The product environmental declaration ¹⁾ contains data on environmentally compatible product design and assessments (RoHS compliance, materials composition, packaging, environmental benefit, disposal).

¹⁾ Documents can be downloaded at <http://siemens.com/bt/download>.

FCC Statement

This equipment has been tested and found to comply with the limits for a Class B digital device, pursuant to part 15 of the FCC Rules. These limits are designed to provide reasonable protection against harmful interference in a residential installation. This equipment generates, uses and can radiate radio frequency energy and, if not installed and used in accordance with the instructions, may cause harmful interference to radio communications. However, there is no guarantee that interference will not occur in a particular installation. If this equipment does cause harmful interference to radio or television reception, which can be determined by turning the equipment off and on, the user is encouraged to try to correct the interference by one or more of the following measures:

- Reorient or relocate the receiving antenna.
- Increase the separation between the equipment and receiver.
- Connect the equipment into an outlet on a circuit different from that to which the receiver is connected.
- Consult the dealer or an experienced radio/TV technician for help.

This device complies with Part 15 of the FCC rules. Operation is subject to the following two conditions:

1. This device may not cause harmful interference, and
2. this device must accept any interference received, including interference that may cause undesired operation

FCC Caution: Changes or modifications not expressly approved by Siemens Switzerland Ltd. could void user authority to operate the equipment. United States representative <https://new.siemens.com/us/en/products/buildingtechnologies/home.html>

Housing

Housing

Color top/bottom	RAL 7035 (light grey) / RAL 7016 (anthracite grey)
Dimensions	per DIN 43 880, see dimensions
Weight with/without packaging	350 g / 300 g

Connection terminals

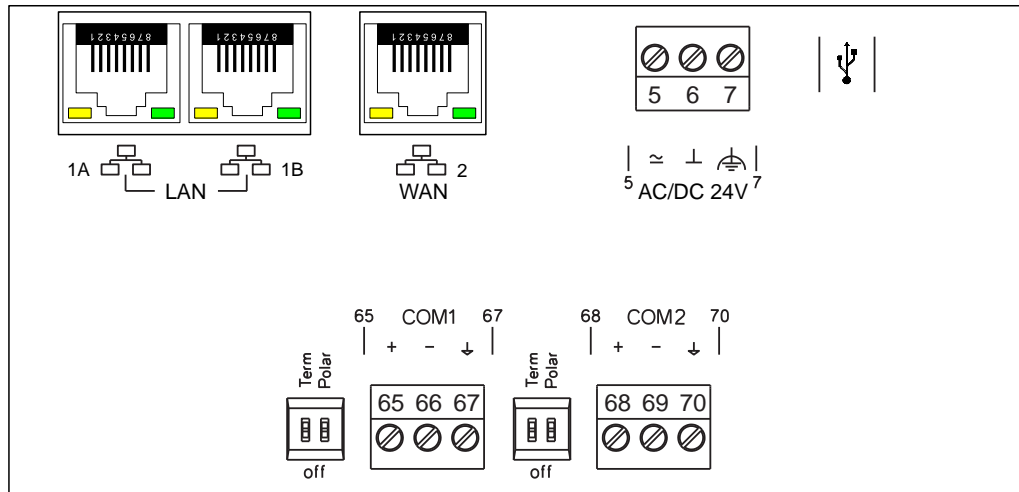

Terminal	Symbol	Description
1A, 1B		2 x RJ45 interface for Ethernet with switch LAN (customer network)
2		1 x RJ45 interface for Ethernet WAN (internet access)
5, 6	\approx , \perp	Operating voltage AC 24 V, DC 24 V
7		Functional ground (must be connected on the installation side with the building grounding system (PE)).
USB		USB interface for 4G dongles
Term	on, off	Switch for bus termination
Polar	on, off	Switch for polarization
65, 66, 67	COM1	Interfaces EIA-485
68, 69, 70	COM2	

Warranty

Technical data on specific applications are valid only together with Siemens products listed under "Equipment combinations". Siemens rejects any and all warranties in the event that third-party products are used.

Dimensions

All dimensions in mm and inches

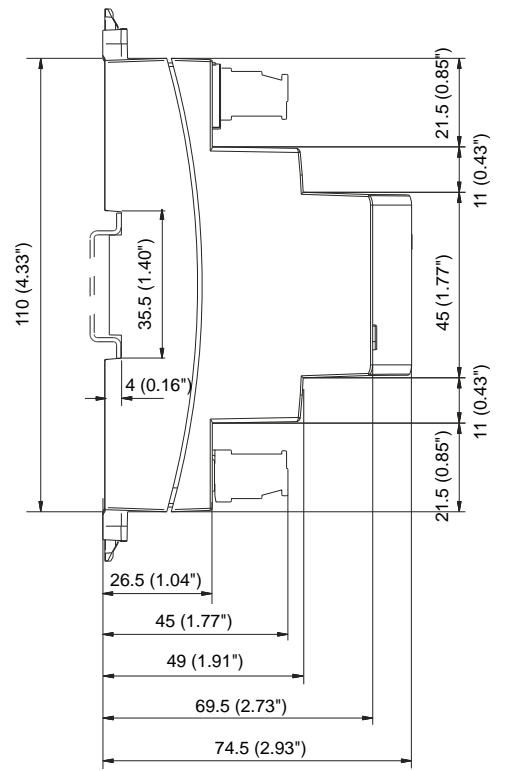
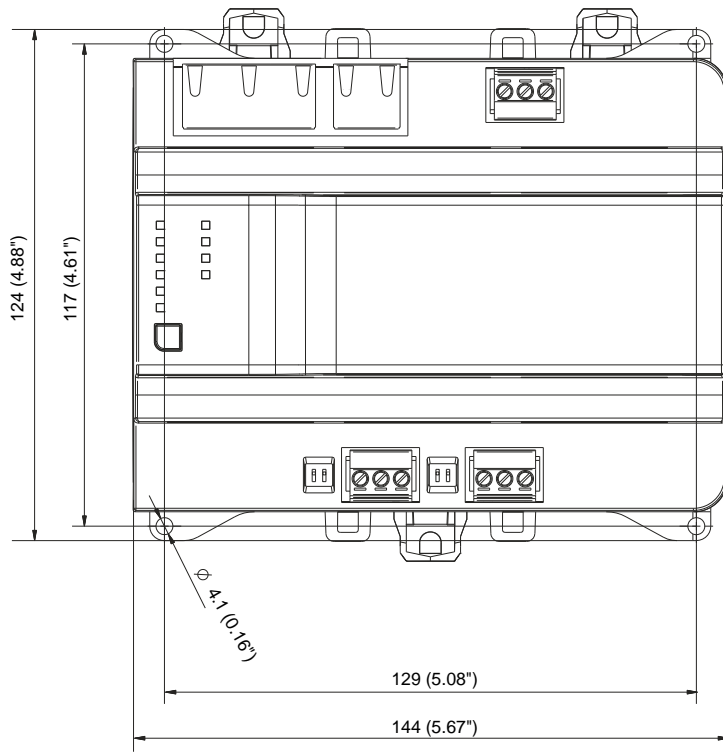

Issued by
Siemens Switzerland Ltd
Smart Infrastructure
Global Headquarters
Theilerstrasse 1a
CH-6300 Zug
+41 58 724 2424
www.siemens.com/buildingtechnologies

© Siemens Switzerland Ltd, 2021
Technical specifications and availability subject to change without notice.

Document ID A6V11974867_en--_b
Edition 2021-08-30