

1 AVAILABLE LANGUAGES

For versions of this Instruction sheet in other languages, see Robur website.

2 APPLICATION

The OTRG005 thermoregulator is a device that can directly manage Robur gas unit heaters: the simple and intuitive display interface allows the user to change the control parameters, switch the unit on/off and change the operating mode; a serial

interface also allows to create cascading systems managed by a single chronothermostat (optional OCDS008), with considerable advantages in terms of temperature control, especially when installing gas unit heaters in large spaces.

3 FEATURES

Figure 3.1 OTRG005 thermoregulator

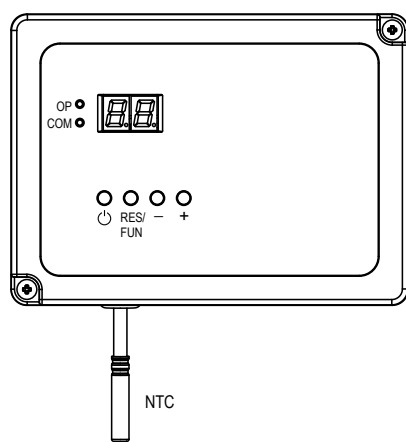

OP	Red led showing gas unit heater operating mode	RES/FUN	Reset/Special functions
COM	Green led showing serial communication status	-	Decrease
		+	Increase
		NTC	Room temperature probe
	On/off		

The main features of this device are:

- ▶ 2-digit 7-segment display
- ▶ 2 led for diagnostic functions and operation signalisation
- ▶ 4 buttons for setup functions
- ▶ 1 NTC probe for ambient temperature measurement
- ▶ 3 high voltage outputs:
 - heat demand
 - summer ventilation
 - unlock the ignition/flame control device
- ▶ 2 high voltage inputs (feedback from the gas heater):
 - operating status
 - ignition/flame control device lockout
- ▶ OpenTherm 2-channel interface for execution of cascaded systems
- ▶ Modbus-RS485 interface for execution of cascading systems

4 TECHNICAL CHARACTERISTICS

Table 4.1 Technical characteristics

		OTRG005 thermoregulator	
Power supply	voltage	V	220 - 240
	frequency	Hz	50 - 60
Operating temperature	minimum	°C	-20
	maximum	°C	+60
Storage temperature	minimum	°C	-40
	maximum	°C	+85
Humidity	maximum at 40 °C	%	95
Degree of protection	IP	-	30
Electric power consumption in standby mode		W	3
Internal fuse		A	6,3
External fuse (recommended)		A	<6,3 (1)
Weight		g	250
Adjustment range (heating mode)		°C	10 ÷ 30
Adjustment range (economy mode)		°C	3 ÷ 25
Adjustment range (safety mode)		°C	3 ÷ 25
Temperature display range		°C	0 ÷ 40
Outputs	heat demand (REQ)	maximum	5A cos φ ≥ 0,4
	summer ventilation (FAN)	maximum	5A cos φ ≥ 0,4
	reset (RES)	maximum	1A cos φ ≥ 0,4
Inputs	operation feedback (OF)	mA	2 - 230 V/50 Hz
	locking feedback (LF)	mA	2 - 230 V/50 Hz
NTC probe			10 kΩ @ 25 °C β=3435

		OTRG005 thermoregulator	
Dimensions	width	mm	150
	height	mm	110
	depth	mm	40
Maximum length of connecting cables	between OTRG005 and gas unit heater	m	10
	between OTRG005 and OCDS008 chronothermostat	m	50
	between OTRG005 and others OTRG005	m	50
	between the most distant OTRG005 device connected with Modbus and the control PC	m	1100

1 The external protection fuse rating must be selected considering the maximum load in the most unfavourable operating mode and conditions.

Figure 4.1 Thermoregulator dimensions

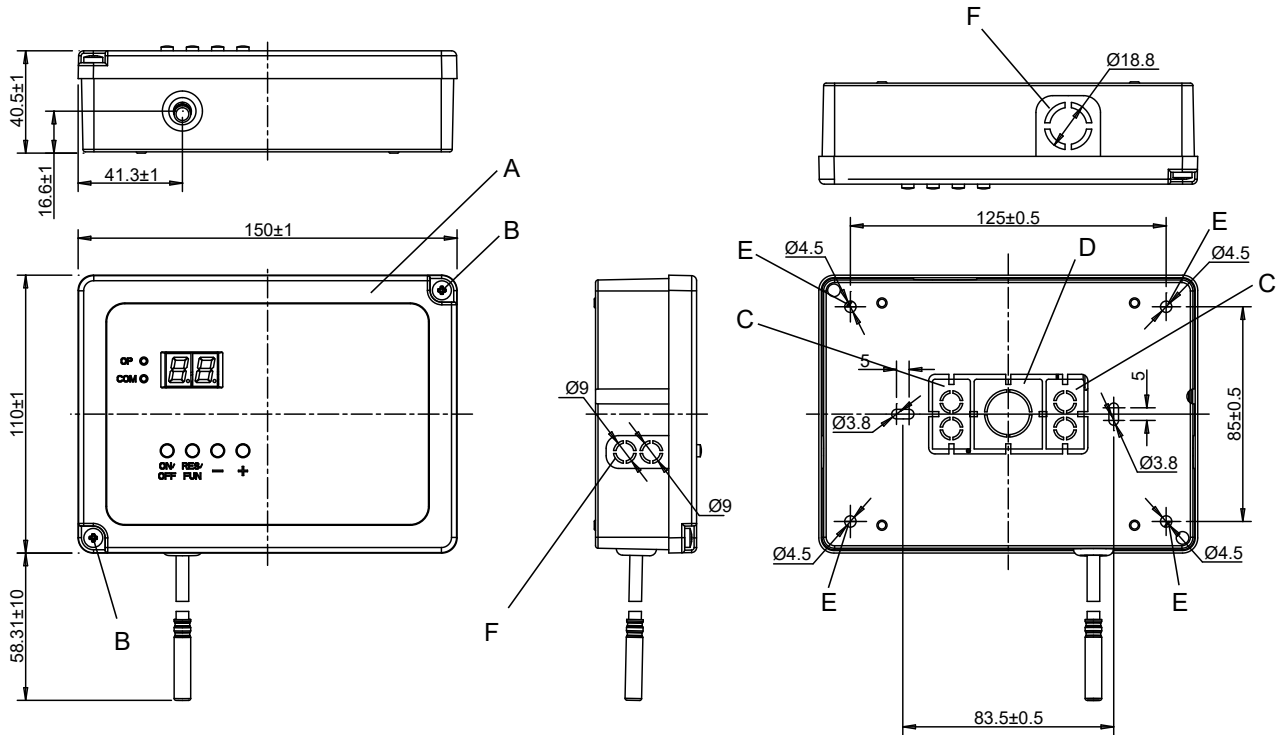

- A Front panel
- B Front panel fastening screws
- C Pre-punched rectangular plates
- D Pre-punched square plate
- E Mounting holes
- F Openings for seating the pre-punched plates

5 INSTALLATION

The OTRG005 thermoregulator is equipped with an ambient probe capable of detecting the temperature of the zone where it is placed. For this reason, it is necessary to place the thermoregulator in the area you want to control, on a wall or other surface that does not affect in negative or positive the detected temperature. It is therefore advisable to avoid installation on non-insulated walls, in areas influenced by hot or cold air currents and near doors.

How to install the thermoregulator (Figure 4.1 p. 2)

1. Locate the position where you want to install the thermoregulator.
2. Remove the thermoregulator front panel (A) by unscrewing the 2 fixing screws (B).
3. Remove the pre-punched plates from the bottom of the thermoregulator box (details C and D).
4. Use the plates to close the three F openings on the sides of the box by inserting them in the appropriate seats.
5. Use the bottom of the box to mark the position of the fixing holes (E) of the thermoregulator on the wall.
6. Drill the holes and fix the box to the wall using expansion screws (not supplied).
7. Perform connections as detailed in Paragraph 10 p. 10.
8. After installation, close the thermoregulator fastening the front panel (A) to the box using the appropriate screws (B).

6 CONNECTION DIAGRAM

Figure 6.1 Connection diagram

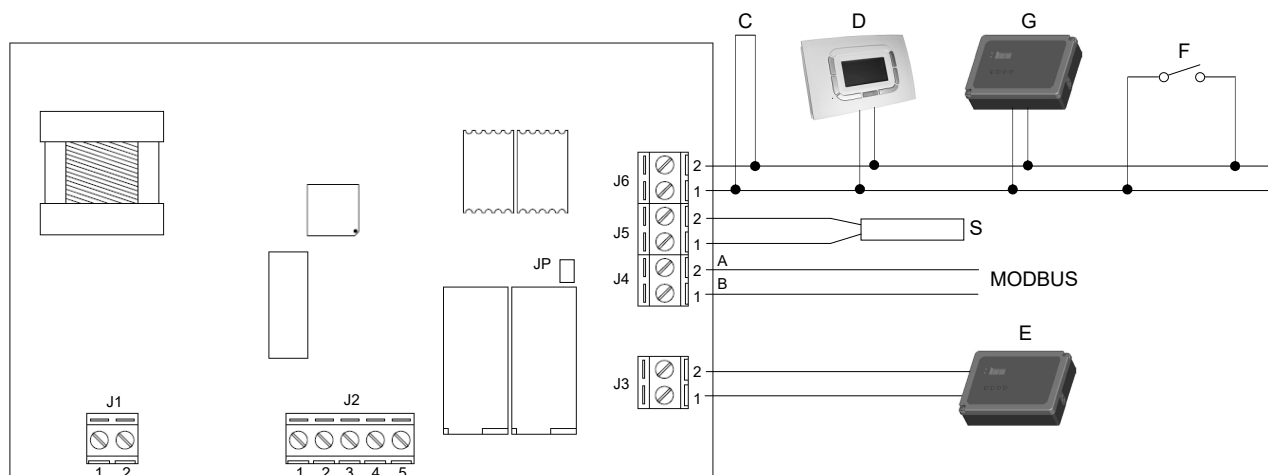

- | | | | |
|---|----------------------------------|---|---|
| C | Electrical bridge (Jumper) | F | External switch |
| D | Chronothermostat OCDS008 | G | Next OTRG005 thermoregulator |
| E | Previous OTRG005 thermoregulator | S | NTC temperature probe (already connected) |

Figure 6.2 Example of connection of several OTRG005 thermoregulators to OCDS008 chronothermostat

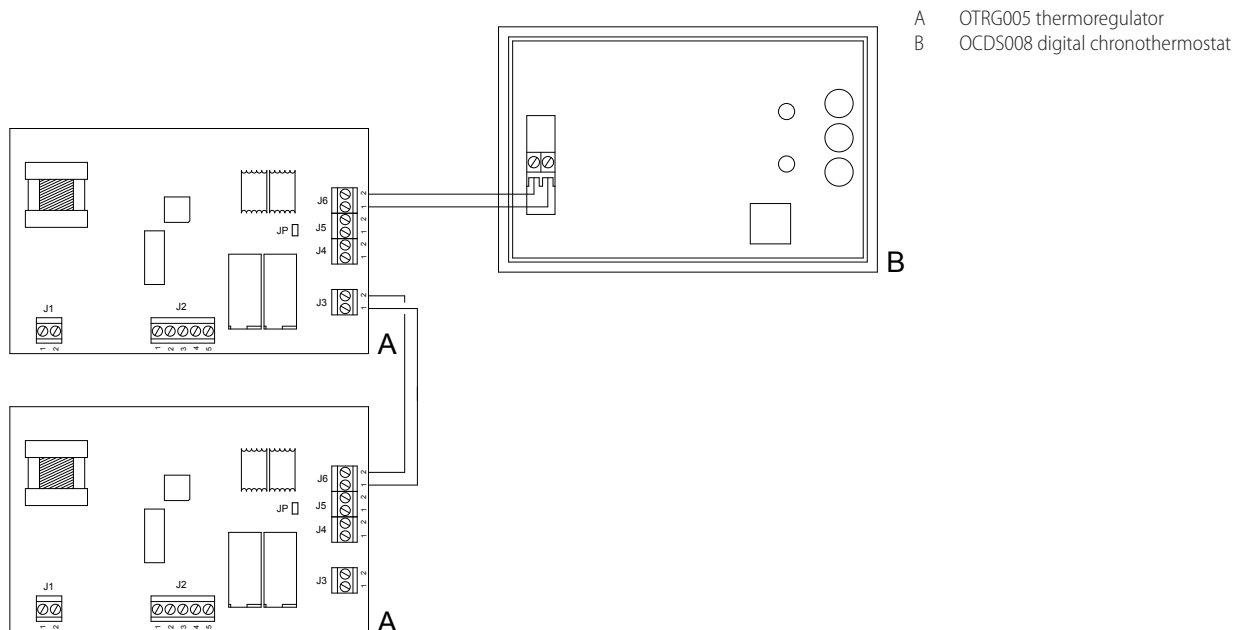

- | | |
|---|----------------------------------|
| A | OTRG005 thermoregulator |
| B | OCDS008 digital chronothermostat |

Figure 6.3 Example of connection of several OTRG005 thermoregulators to an external request

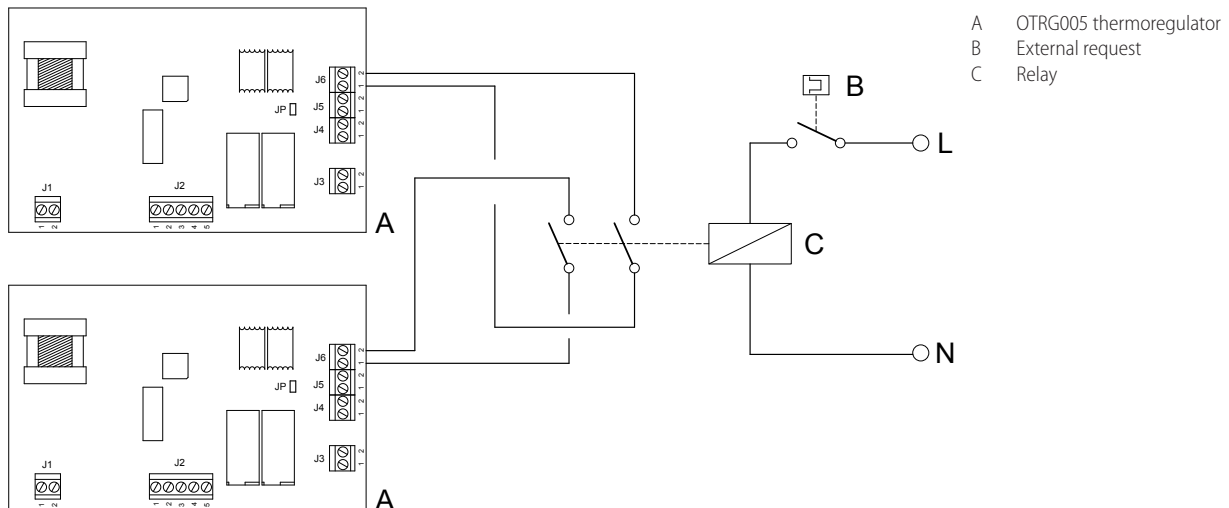

7 OPERATION

The flexibility of the OTRG005 thermoregulator allows it to be combined with Robur gas unit heaters.

The device can operate in the following modes:

- ▶ Local (single).
- ▶ Remote independent (single or multiple), with OCDS008 or OSWR000 optional.
- ▶ Remote assisted (single or multiple), with OCDS008 or OSWR000 optional.

Each mode allows the following operating states:

- ▶ On/off.
- ▶ Summer ventilation (activation of the gas unit heater fan).
- ▶ Heating (on/off or modulating).
- ▶ Economy mode heating.

In all local operating modes (Paragraph 7.5 p. 5), it is possible to force the off state (by pressing the button) and unlock the gas unit heater ignition/flame control device (by pressing the RES/FUN button) (Figure 3.1 p. 1).

7.1 HEATING MODE OPERATING LOGIC

This type of device has a logic for managing heating mode operations based on three main parameters:

- ▶ Setpoint (Tsetpoint): it's the target temperature inside the heated room. When the room temperature probe detects that the set value has been achieved, the gas unit heater burner is switched off.
- ▶ Hysteresis (Hy): this parameter is used to prevent the gas unit heater from switching on and off continuously in an attempt to achieve and maintain the required setpoint. This value indicates how much the temperature read by the room temperature probe must go down with respect to the setpoint before the burner is restarted.
- ▶ Temperature differential (Di): it's a temperature range useful for operating the unit in modulation, between the maximum and minimum power.

Figure 7.1 Heating mode diagram (example values)

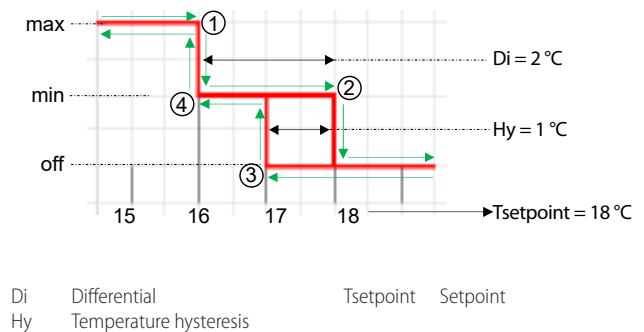

Figure 7.1 p. 4 shows the influence of hysteresis and differential parameters on the operating mode of a modulating gas unit heater.

If the hysteresis value is higher than the differential value, the gas unit heater and the fan will only start when the ambient temperature is below the value set by the hysteresis (Tsetpoint-Hy). Assume the setpoint temperature is set to 18 °C, the differential to 2 °C and the hysteresis to 1 °C.

1. Starting from a temperature lower than 15 °C the gas unit heater is started at full power until a temperature of 16 °C is reached (setpoint - differential).
2. Once the temperature reaches 16 °C, we enter the differential range of 2 °C, so that the gas unit heater switch from full power to minimum power, continuing to heat until it reaches the setpoint of 18 °C. The burner is then automatically switched off.
3. The room temperature starts to decrease until it falls below the hysteresis parameter value (i.e. below 18 °C - 1 °C = 17 °C) so that the burner is switched on again at minimum power and starts supplying heat again. From here you can have two different conditions:
 - a. The temperature begins to increase (the heat supplied by the gas unit heater in modulation is sufficient to cover the demand) until it reaches again point 2 (18 °C) again, repeating the hysteresis cycle.
 - b. The heat supplied by the gas unit heater in modulation is not sufficient to cover the demand, so the room

temperature continues to decrease until point 4 (16 °C), reaching the differential value (2 °C), then the gas unit heater switches to the maximum power to try to restore the required setpoint.

7.2 MODULATION MANAGEMENT

The gas unit heater operation can be set using the Mo parameter (Paragraph 9 p. 9):

- ▶ with modulation (Mo set to 1)
- ▶ always at minimum power (Mo set to 0)
- ▶ always at maximum power (Mo set to 2)

When the Mo parameter is set to 1, the burner operates in modulation: if the room temperature is lower than that of the setpoint minus the Di differential, the burner operates at the maximum power. Once the differential threshold is achieved, the burner enters in modulation until the setpoint temperature is achieved, and then it will switch off.

Modulation is disabled if the anti-condensation mode is active (Paragraph 7.3 p. 5).

Anyway, when the setpoint temperature is achieved, the gas unit heater will switch off.

7.3 ANTI-CONDENSATION MODE MANAGEMENT

If the gas unit heater is set to modulation (parameter Mo set to 1), it is possible to ensure that the gas unit heater always remains at maximum power below a given ambient temperature, in order to avoid potential condensation.

To activate this operating mode, set the AC parameter (Paragraph 9 p. 9) to a value other than of.

The value of the AC parameter corresponds to the ambient temperature below which the gas unit heater will always be at maximum power. Above this, the gas unit heater operation will be modulating.

7.4 KEYPAD LOCK

This function, if enabled via the LF parameter (Paragraph 9 p. 9), allows you to inhibit the use of the keys, to prevent unwanted changes to the settings.

The keypad lock is highlighted by the flashing decimal point (Figure 7.2 p. 5).



Figure 7.2 Display with locked keyboard



The keypad lock remains active even if the device is restarted.



Keypad unlock

- Press the  and + keys simultaneously for 15 seconds.
- The key symbol  is shown for 2 seconds on the display.
- The keypad is now operational again.
- If no key is pressed for 1 minute, the keypad lock is restored.



The keypad lock function is not activated when you are in the parameter menu.

7.5 LOCAL MODE

In this mode the device is able to:

- ▶ Switch the gas unit heater on and off.
- ▶ Perform the reset of any gas unit heater lockout (when possible).
- ▶ Adjust the room temperature.
- ▶ Modulate the burner of the connected gas unit heater (using the Mo parameter, Paragraph 9 p. 9).

The local mode is suitable to standalone operation (neither OpenTherm nor Modbus connection).

Using the - (decrease) and + (increase) buttons (Figure 3.1 p. 7) it is possible to adjust the setpoint temperature (Ht) for space heating (range 10÷30 °C) or to activate summer ventilation (CL setpoint, < 10 °C).

In summer ventilation mode (CL setpoint), the fan of the gas unit heater is always on.

During heating mode the room temperature, measured by the NTC temperature probe, is always compared with the required setpoint, managing the start or stop of the burner according to the diagram shown in Figure 7.3 p. 5.

Figure 7.3 Burner status depending on ambient temperature

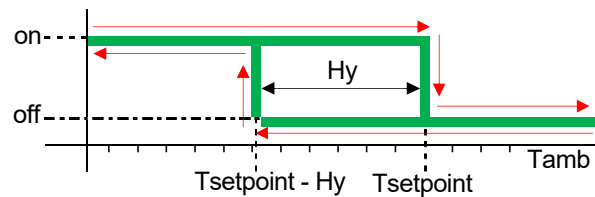

Hy Temperature hysteresis
Tsetpoint Setpoint
Tamb Ambient temperature

HY represents the temperature hysteresis, i.e. a threshold which avoids the continuous switching on/off of the gas unit heater in the presence of a room temperature close to the setpoint (this value can be set via the user interface, Paragraph 9 p. 9).

For additional details on the hysteresis temperature operation refer to Paragraph 7.1 p. 4.

The value of the Di differential can be modified through the parameters menu, Paragraph 9 p. 9.

For additional details on the differential operation refer to Paragraph 7.1 p. 4.

7.5.1 J6 external request operation

J6 input can be used as:

1. External on/off request (in heating mode), with Lo parameter disabled (Paragraph 9 p. 9).
2. Switch for heating mode with economy setpoint (Lo) or with normal setpoint (Ht), with Lo parameter enabled (Paragraph 9 p. 9).



The Ht setpoint is the normal Tsetpoint value that is set for heating, while the economy setpoint (Lo) is set by the appropriate parameter Lo (Paragraph 9 p. 9).

7.5.1.1 J6 operation with Lo parameter disabled

This function is useful when you want to start the heating or ventilation through an external request to the OTRG005 thermoregulator (e.g. programmable timer, external

switch, etc.).



Check display status (Figure 7.4 p. 6):

1. If no temperature (- -) is shown on the display, the device is switched off. To turn it on press .
2. If the display shows a number, e.g. 12, it means that the device is active; the number indicates the temperature read by the NTC probe.
3. In this case, the device correlates the temperature read by the probe with the required setpoint.
4. **If the setpoint temperature is below 10 °C (Tsetpoint = CL) then contact J6 can be used for:**
 - Activate summer ventilation, closing J6 contact.
 - Switch off the gas unit heater, opening J6 contact.
5. **If the setpoint temperature is between 10÷30 °C (Tsetpoint = 10÷30 °C) then contact J6 can be used for:**
 - Activate heating mode, closing J6 contact.
 - Switch off the gas unit heater, opening J6 contact.

Figure 7.4 J6 contact used as on/off switch (Lo parameter disabled)

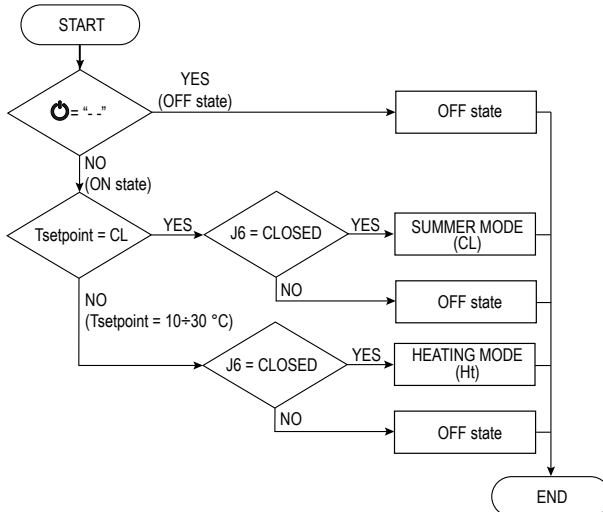

7.5.1.2 J6 operation with Lo parameter enabled

This function is useful when you want to manage the gas unit heater with two different setpoints through an external request to the OTRG005 thermoregulator.



Check the required setpoint (Figure 7.5 p. 6):

1. If the setpoint temperature is below 10 °C (Tsetpoint = CL) and the device is on (display message other than - -), contact J6 can be used for:
 - Activate summer ventilation, closing J6 contact.
 - Switch off the gas unit heater, opening J6 contact.
2. If the temperature setpoint is between 10÷30 °C (Tsetpoint = 10÷30 °C), the unit is heating in one of the following modes:
 - Economy mode heating with Lo setpoint, if the ECO_HEAT flag is enabled.
 - Heating with Ht setpoint if the ECO_HEAT flag is disabled.

Figure 7.5 J6 contact used as summer/winter mode switch (Lo parameter enabled)

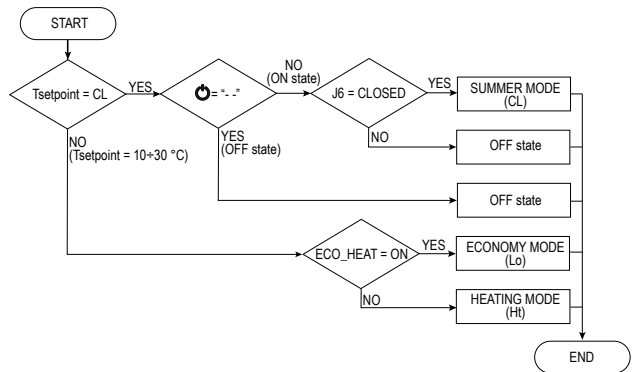

The activation of the gas unit heater modulation is entrusted only to the setting of the Mo parameter (Paragraph 7.2 p. 5). The purpose of the parameter Lo is to be able to use, for the heating function, two different setpoints, respectively Lo for the economy mode (useful for example for nighttime operation) and Ht for the normal mode (useful for example for daytime operation).

7.5.1.3 ECO_HEAT setting



ECO_HEAT is a flag that indicates if the system has to work in economy mode or in heating mode.

The ECO_HEAT flag can be changed manually by the button (Figure 7.6 p. 6) or by an external request (e.g. timer) connected to J6 terminal (Figure 7.7 p. 7).

Manual operation

When the setpoint temperature is lower than 10 °C, summer ventilation is activated by pressing the button. When the setpoint temperature is between 10÷30 °C, ECO_HEAT flag is activated by pressing the button.

Figure 7.6 Manual setting of the ECO_HEAT flag

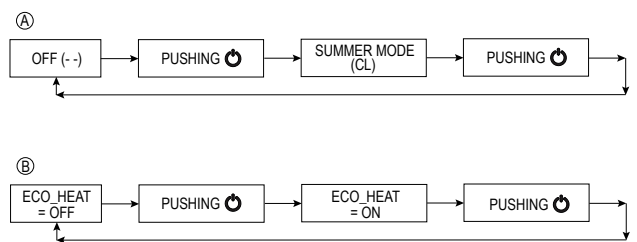

A Tsetpoint = CL (< 10 °C) B Tsetpoint = 10÷30 °C

Automatic operation

Closing J6 contact, if open, deactivates ECO_HEAT flag (economy), while opening the contact activates the flag. During operation in economy mode, the temperature control work in the same way as described above, but using the Lo parameter value as the setpoint temperature, which is different than the standard setpoint.

Figure 7.7 Automatic setting of the ECO_HEAT flag

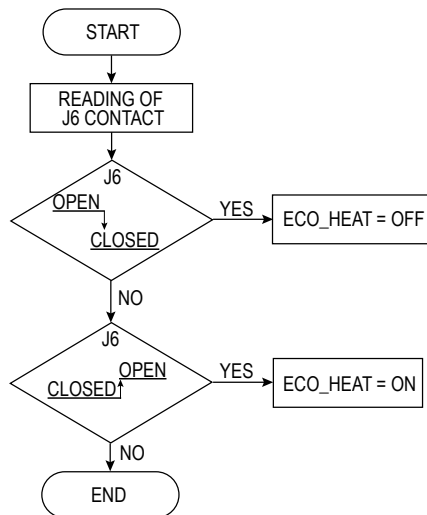

7.6 REMOTE MODE

The OTRG005 thermoregulator can be used individually or connected to the following central control systems (optional) (Figure 7.8 p. 7):

- ▶ OCDS008 digital chronothermostat that uses an OpenTherm communication. With this system, it is possible to control up to 10 OTRG005 devices connected to as many gas unit heaters. For additional information regarding operation with the OCDS008 digital chronothermostat, please refer to the relative instructions.
- ▶ OSWR000 Genius software, for installation on a PC, using Modbus communication. With this system, it is possible to control up to 100 OTRG005 devices connected to as many gas unit heaters. For additional information on operation with OSWR000 Genius software, refer to the relative instructions.

Figure 7.8 Connection diagrams for remote mode (assisted or independent)

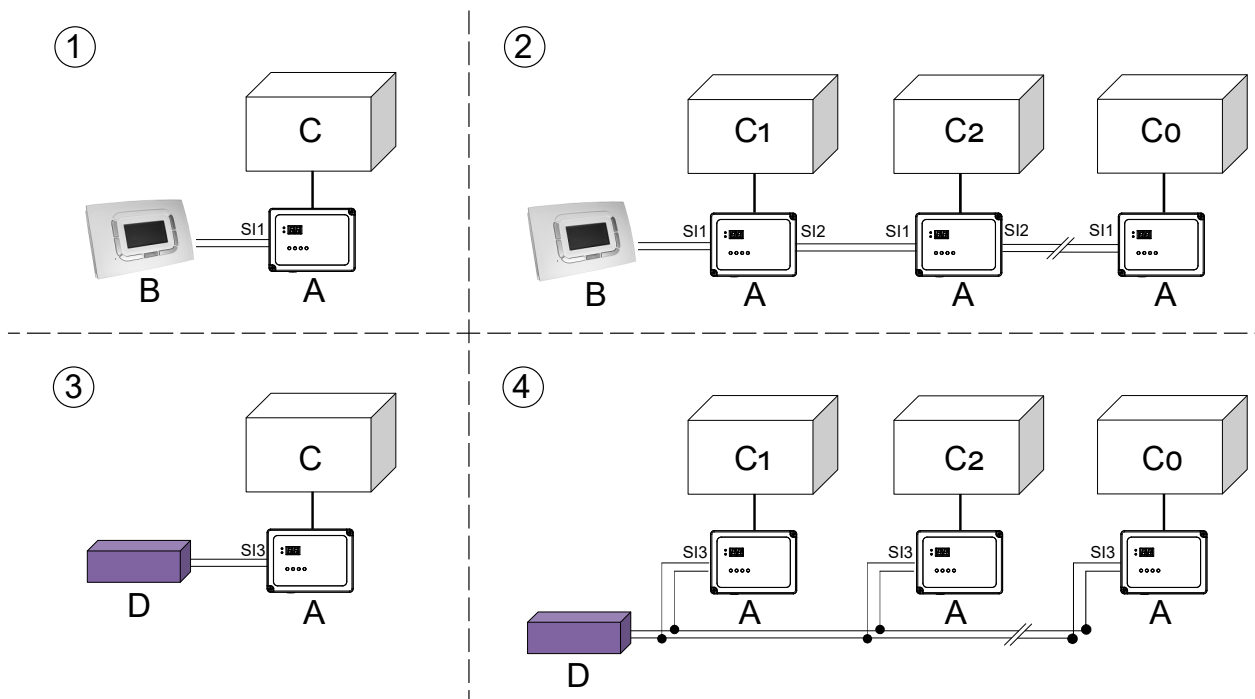

- 1 Single unit connection with OpenTherm
- 2 Cascading systems connection with OpenTherm (up to 10 units)
- 3 Single unit connection with Modbus
- 4 Multiple connection connection with Modbus (up to 100 units)

- A OTRG005 thermoregulator
- B OCDS008 chronothermostat
- C Gas heater
- D Modbus master (PC with OSWR000 Genius software)

7.6.1 Remote independent mode

i For operation in this mode, the OCDS008 digital chronothermostat or the OSWR000 Genius software is required.

In this mode, the OCDS008 digital chronothermostat manages the gas unit heater operation (off - summer ventilation - heating - economy) while the room temperature control is managed directly by the OTRG005 device, by comparing the temperature measured by the NTC probe with the setpoint set on the OCDS008 chronothermostat.

This mode is useful when the chronothermostat is far from the comfort zone, or when more than one OTRG005 thermoregulator

(and therefore more than one gas unit heater) are connected to the chronothermostat.

In case of summer ventilation operation, the fan operation is totally controlled by the OCDS008 digital chronothermostat, in accordance with the daily programming or with the manual setting.

During heating operation, the OTRG005 thermoregulator compares the room temperature measured by the NTC probe with the setpoint set on the chronothermostat.

For modulation management, see Paragraph 7.2 p. 5.

7.6.2 Remote assisted mode

For operation in this mode, the OCDS008 digital chronothermostat or the OSWR000 Genius software is required.

Remote assisted mode can be used when the OCDS008 control device is installed within the comfort zone.

To activate this operating mode the Md parameter must be set to 1 (Paragraph 9 p. 9).

In this mode the management of the system is entrusted entirely to the OCDS008 control device, thanks to which it is possible:

- ▶ Set the gas unit heaters operating mode (off - summer ventilation - heating - economy).
- ▶ Set temperatures and time programming of the gas unit heaters.
- ▶ Identify the presence of gas unit heaters faults.
- ▶ Unlock the gas unit heaters in case of faults.

In case of summer ventilation operation, the fan operation is totally controlled by the OCDS008 digital chronothermostat, in accordance with the daily programming or with the manual setting.

In heating mode, the room temperature is read by the NTC temperature probe of the OCDS008 chronothermostat and compared with the setpoint temperature according to manual or automatic mode (for further information refer to the instructions of OCDS008 chronothermostat).

If the OSWR000 Genius software is used, the ambient temperature of the specific zone will be the average of the temperatures read by the NTC probes of the OTRG005 thermoregulators for that specific zone.

The burner is on until the setpoint temperature is achieved, after which it is switched off until the hysteresis threshold is achieved (Tsetpoint – HY). In this case, HY and Tsetpoint are the hysteresis and setpoint temperatures of the OCDS008 digital chronothermostat respectively.

For modulation management, see Paragraph 7.2 p. 5.

7.7 NTC PROBE

The NTC probe allows ambient temperature detection: it protrudes through a suitable cable (length of about 7 cm) from the bottom side of the device and can be calibrated via the relative offset parameter (oF), which allows subtracting a fixed gradient to compensate for any overheating related to the installation or environment.

In the event of a fault, the heating function will not be available, except in case of remote assisted mode: in this case, the temperature read by the thermoregulator probe is ignored by the system.

7.8 DETAILS ON REMOTE DEVICE OPERATION

For the operation, adjustment and management of the OTRG005 devices connected to the OCDS008 digital chronothermostat (using OpenTherm protocol) and to the OSWR000 Genius software (using Modbus protocol), refer to the specific instructions. Please note that, in case of loss of OpenTherm or Modbus communication between the OTRG005 devices and the remote system, due to any reason (failure of the OCDS008 chronothermostat, crash of the Genius software or of the PC that host it, interruption or interference on the communication line), a timeout time of 120 sec (2 minutes) is started, after which the connected devices:

- ▶ If the safety temperature parameter is disabled (St = of, default value) (Table 9.1 p. 9), the gas unit heater is switched off.
- ▶ If the safety temperature parameter is enabled (St = between 3 and 25 °C), the gas unit heater is controlled using the safety temperature as the new setpoint. In this case, the display will show the SM value (safety mode).

If activated, the safety mode can be deactivated by turning off the power to the device, or by pressing the , - or + buttons.

The safety mode is deactivated by default, and is activated by setting a setpoint temperature in the St parameter (range 3 ÷ 25 °C).

8 USER INTERFACE

The device has an interface through which the user can understand the operating status of the managed gas unit heater and provide the setup and all the actions necessary for its operation.

8.1 DISPLAY

The display allows you to view the ambient temperature, setpoint, and device setup parameters, as shown in Table 8.1 p. 8.

Table 8.1 Display views

Message	Description
--	Off (via the button in all modes)
--.	Off (via the button in all modes) with active keypad lock
	Rotary segment (system initialization: only after power-on)
23	Ambient temperature (measured by NTC probe)
23	Setpoint temperature (at keystroke - / +): the "CL" indication the demand for summer ventilation

Message	Description
E1	Error 1 - Ignition/flame control device block
E2	Error 2 - NTC probe fault
E4	Error 4 - Overcoming 5 unlocks in 15 Minutes (remote)
CL	Summer ventilation activated (temporary message, duration about 2 seconds, flashing), when the setpoint temperature is set to a value lower than 10 °C
HE	Heating activated (temporary message, duration about 2 seconds, flashing), when the setpoint temperature is set to a value between 10÷30 °C
Lo	Economy mode heating activated (temporary message, about 2 seconds, flashing)
SN	Safety mode activated. It activates when the device loses Modbus or OpenTherm connection
07	Temporary keypad unlock (temporary message, duration about 2 seconds) if the keypad lock function has been activated

8.2 OP LED (RED) - GAS HEATER OPERATING LED

The OP led indicates the operating status of the managed gas unit heater: Figure 8.1 p. 9 shows the various views provided.

Figure 8.1 OP led (red) views

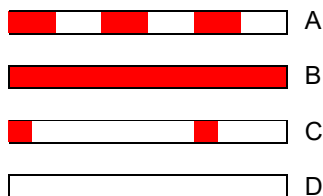

- A Heating mode: ignition, low power operation
- B Heating mode: full power operation
- C Summer mode: fan activated
- D All other states (off)

Figure 8.2 COM led (green) views

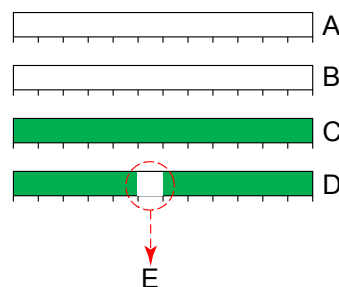

- A Local mode (J6 contact open, led off)
- B Local mode (J6 contact closed, led off)
- C Remote mode (OpenTherm communication)
- D Remote mode (Modbus communication)
- E Receiving data from remote control (Modbus mode only)

8.3 COM LED (GREEN) - BUS PRESENCE LED

The COM led indicates the presence of a remote communication (OpenThermo® or Modbus) as shown in Figure 8.2 p. 9.

In the case of Modbus communication, a brief blinking signal signals the receipt of a command by the master remote control.

8.4 BUTTONS

Table 8.2 p. 9 shows the functions of the device buttons.

Table 8.2 Buttons functions

Button	Functions
	• Turning the gas unit heater on/off (Lo parameter disabled)
RES/FUN	• Unlocking the flame controller/ignition device (press for at least 3 seconds) • Access to the parameter edit menu (press for at least 10 seconds) • Scrolling parameters within the menu
-	• Decrease setpoint temperature (local mode) • Summer ventilation activation (local mode) • Editing (decrease) of the selected parameter
+	• Increase setpoint temperature (local mode) • Summer ventilation deactivation (local mode) • Editing (increase) of the selected parameter

9 PARAMETERS MENU

This menu allows you to modify some parameters used in the thermoregulation functions.



How to access and edit parameters

- Press the RES/FUN button for at least 10 seconds until the blinking message appears.
- To change the mode (Md) parameter, wait 2 seconds: the set





value will show (flashing). Use - or + buttons to decrease or increase the parameter value.

- To scroll through the other parameters, which are also flashing, press the RES/FUN button and change the selected parameter value as indicated in step 2.
- To exit the menu and save the changes, scroll through all the parameters using the RES/FUN button until the temperature read by the NTC probe appears on the display.

Table 9.1 p. 9 shows available parameters.

Table 9.1 Parameters menu

Parameter	Description	Setting	Default
	Mode (Md) Allows setting the remote assisted or remote independent mode when the device is connected to a remote control (OCDS008 or OSWR000).	0. remote independent 1. remote assisted	0
	Hysteresis (HY) Allows setting the hysteresis temperature (between one shut-down and the next burner ignition).	0.1 ÷ 3.0 °C	0.5
	Offset (oF) Allows subtracting from the temperature read by the NTC probe a specific value, to calibrate the reading of the temperature probe.	0.0 ÷ 5.0 °C	1.5
	Address (Ad) To be used in case of Modbus communication; it provides each OTRG005 device with a specific address, which must be different from that of all the other devices connected to the same network. The value is hexadecimal.	01 ÷ F7	01
	Modulation (Mo) Allows operation of the gas unit heater in modulation or in on/off mode.	0. on/off at minimum power 1. with modulation 2. on/off at maximum power	1

Parameter	Description	Setting	Default
	Differential (di) Allows setting the temperature differential between maximum power and economy operation.	0.0 ÷ 4.0 °C	1.0
	Economy (Lo) Allows, in local mode, the operation of the gas unit heater in economy mode through J6 contact (for further details see Paragraph 7.5.1.2 p. 6).	of economy mode disabled 02 ÷ 25 °C economy mode setpoint	of
	Safety temperature (St) Allows setting the local setpoint temperature when the device is connected to a remote control system (OCDS008 or OSWR000) and loses OpenTherm or Modbus communication.	of safety mode disabled 03 ÷ 25 °C safety mode setpoint	of
	Anti-condensation temperature (AC) Allows setting the anti-condensation temperature, i.e. the ambient temperature below which the gas unit heater will always be activated at maximum power, if the parameter Mo is set to value 1 (with modulation). If the Mo parameter is set to 0, the gas unit heater will always be activated at minimum power, even if the anti-condensation function is active.	01 ÷ 25 °C anti-condensation mode threshold	of
	Keypad lock (LF) Allows setting the keypad lock. If active, the decimal point on the display flashes.	of disabled on enabled	of

10 CONNECTIONS TO THE GAS UNIT HEATER



How to connect the thermoregulator to the Next-R gas unit heater

Connection of the thermoregulator is made on the wiring terminal block located in the electrical panel inside the unit.

1. Access the gas unit heater terminal block.
2. Remove 27 and 28 temporary jumpers on the terminal block.
3. Use cable 28 to make an electrical bridge between terminals NC and 2 (Figure 10.1 p. 11).
4. Use FRORR 7x1 mm² cable (available as OCVO015 optional, with 5 m length).
5. Route the cable through the pre-punched hole on the square plate.
6. Make electrical connections as described in Figure

10.1 p. 11 and in Table 10.1 p. 11.



The cable may not be longer than 10 metres.

7. If the device is connected to other devices and/or to remote controls (OCDS008 or OSWR000) use the pre-punched holes provided on the rectangular side plates and follow the instructions in Figure 7.8 p. 7 and 6.1 p. 3 to make the connections.



If the device is used in local mode without using an external request (Paragraph 7.5.1 p. 5), close J6 connector with an electrical bridge.

Figure 10.1 Connections between the thermoregulator and the gas unit heater

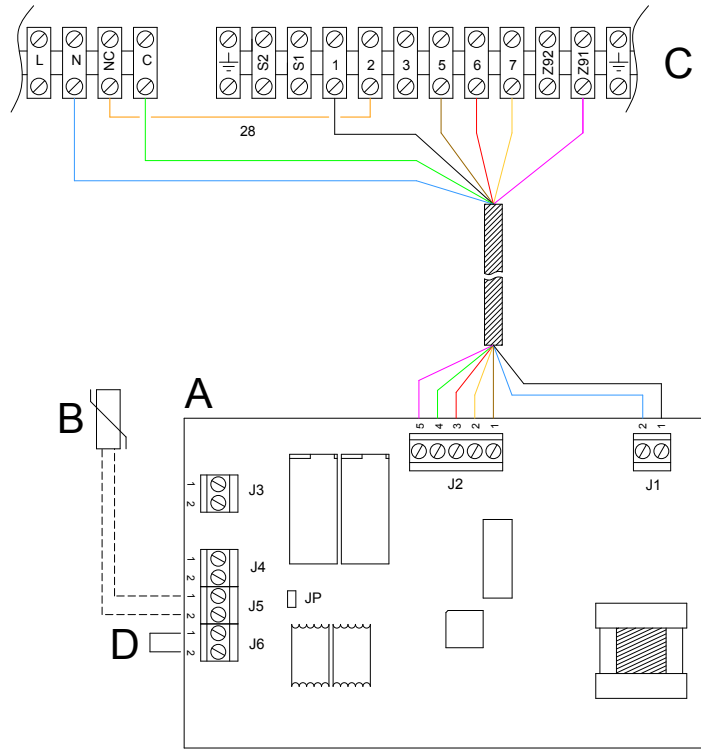

- A OTRG005 thermoregulator
- B NTC temperature probe (supplied)
- C Next-R gas unit heater terminal block
- D J6 electrical bridge

Table 10.1 OTRG005 thermoregulator connections

Connector	Terminal	OTRG005 thermoregulator			Next-R Terminal
		Type	Description		
J1	1	Input	L	phase	1
	2	Input	N	neutral	N
J2	1	Input	OF	Gas unit heater operation feedback	5
	2	Output	RES	Reset of ignition/flame control device	7
	3	Input	LF	Flame control locking state reading	6
	4	Output	FAN	Control of the gas unit heater fan(s)	C
	5	Output	REQ	Control of the ignition/flame control device	Z91
J3	1	Input/output	SI2	OpenTherm master interface (towards any subsequent thermoregulator of the control chain)	-
	2				-
J4	1	Input/output	SI3	Modbus RS-485 serial interface (Terminal 1 = signal "B" – Terminal 2 = signal "A")	-
	2				-
J5	1	Input	NTC probe input		-
	2				-
J6	1	Input/output	SI1	OpenTherm slave interface (towards OCDS008 digital chronothermostat or any previous thermoregulator of the control chain)	-
	2				-
JP	/	Input	Selection jumper "impedance 120 Ω"		-

INDEX OF CONTENTS

1 Available languages	p. 1	7.4 Keypad lock.....	p. 5
2 Application	p. 1	7.5 Local mode.....	p. 5
3 Features	p. 1	7.6 Remote mode.....	p. 7
4 Technical characteristics	p. 1	7.7 NTC probe.....	p. 8
5 Installation	p. 2	7.8 Details on remote device operation	p. 8
6 Connection diagram	p. 3	8 User interface	p. 8
7 Operation	p. 4	8.1 Display	p. 8
7.1 Heating mode operating logic.....	p. 4	8.2 OP Led (red) - Gas heater operating led	p. 9
7.2 Modulation management.....	p. 5	8.3 COM led (green) - BUS presence led	p. 9
7.3 Anti-condensation mode management.....	p. 5	8.4 Buttons.....	p. 9
		9 Parameters menu	p. 9
		10 Connections to the gas unit heater	p. 10

DISPOSAL

The appliance and all its accessories must be disposed of separately in accordance with the regulations in force.



Use of the WEEE symbol (Waste Electrical and Electronic Equipment) indicates that this product cannot be disposed of as household waste. Proper disposal of this product helps to prevent potential negative consequences for the environment and human health.