



1 APPLIANCE POSITIONING

The unit must be installed in the room to be heated.

1.1 WHERE TO INSTALL THE APPLIANCE

 The wall or structure on which the unit is to be installed must be load-bearing or, in any case, suitable for supporting its weight.

 Installation must not be made on walls with poor strength that do not guarantee adequate resistance to the stresses produced by the unit. The manufacturer does not assume any responsibility if the appliance is installed on surfaces or walls that are not suitable for supporting its weight.

 Vertical downflow gas unit heaters must be installed with the warm air delivery downwards. The gas unit heater

must be horizontal in relation to its longitudinal axis.

 The appliance's flue gas exhaust must not be immediately close to openings or air intakes of buildings, and must comply with safety and environmental regulations.

To obtain the maximum system efficiency it is advisable to comply with the following rules:

- ▶ Make sure that the air flow does not directly impinge on the staff (by tilting the grille louveres appropriately).
- ▶ Take any obstacles into account (pillars or other).
- ▶ Consider the length of throw of the appliance (see technical data tables of the appliance).
- ▶ For better heat distribution in the case of multiple unit installations, create alternate flows of warm air (see Figure 1.1 p. 1).
- ▶ In some cases it may also be suitable to place the units close to the main doors, so that they can also operate as air barriers when doors are opened.

Figure 1.1 Airflow distribution

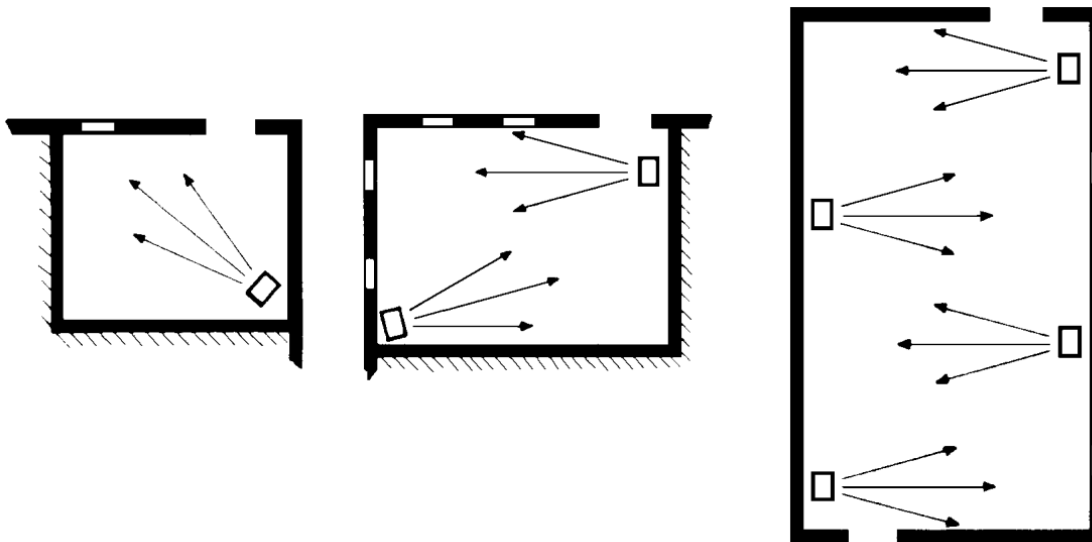

2 MINIMUM CLEARANCE DISTANCES

2.1 DISTANCES FROM COMBUSTIBLE OR FLAMMABLE MATERIALS

- ▶ Keep the appliance away from combustible or flammable materials or components, in compliance with applicable regulations.

2.2 CLEARANCES AROUND THE APPLIANCE

 The minimum clearance distances are required for safety, operation and maintenance.

Axial gas unit heaters

Figure 2.1 Clearances

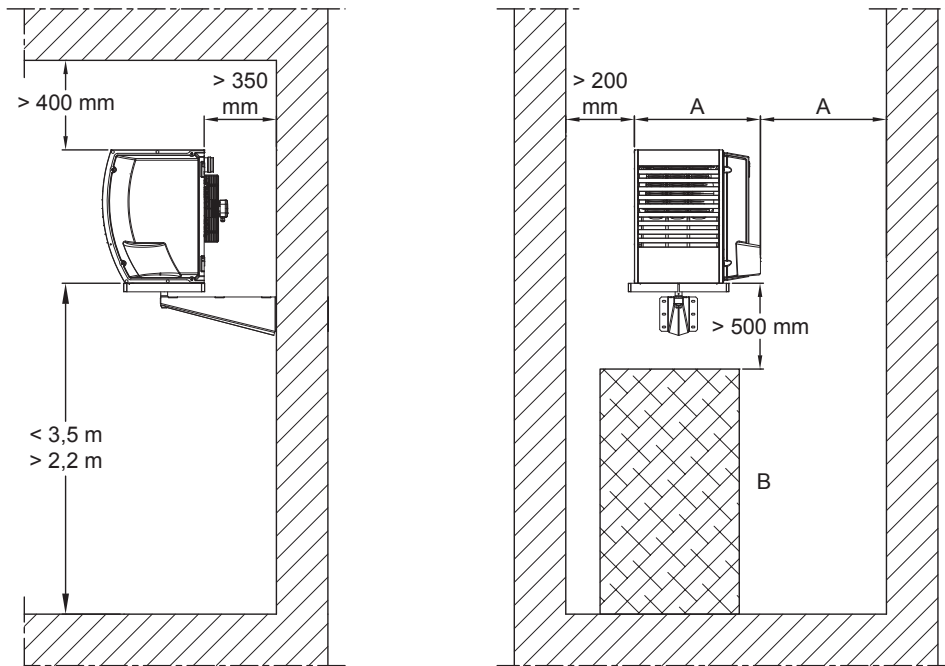

- A Gas unit heater width
- B Object or structure underneath the gas unit heater

i The recommended height from the floor to the gas unit heater base is 2,2 to 3,5 m (see Figure 2.1 p. 2). Installing the gas unit heaters at heights below 2,2 m from the floor is not recommended.

Centrifugal gas unit heaters

The position of gas unit heaters with centrifugal fan must consider the position of the warm air duct. This must be suitably sized and verified in relation to the air flow rate and the head of the centrifugal fan.

i The recommended height from the floor to the gas unit heater base is 2,5 to 3,5 m (see Figure 2.1 p. 2). We do not recommend installing the gas unit heaters at heights below 2,5 m from the floor.

Vertical downflow gas unit heaters

A minimum distance of 1 m from all sides is required around the vertical downflow gas unit heater.

Table 2.1 p. 2 shows recommended minimum and maximum heights for installation and the air jet range to the floor, depending on the actual height of the gas unit heater from the floor (indicated with H).



For vertical downflow gas unit heaters, the louvres of the delivery grille must be in the fully open position.

Figure 2.2 Clearances

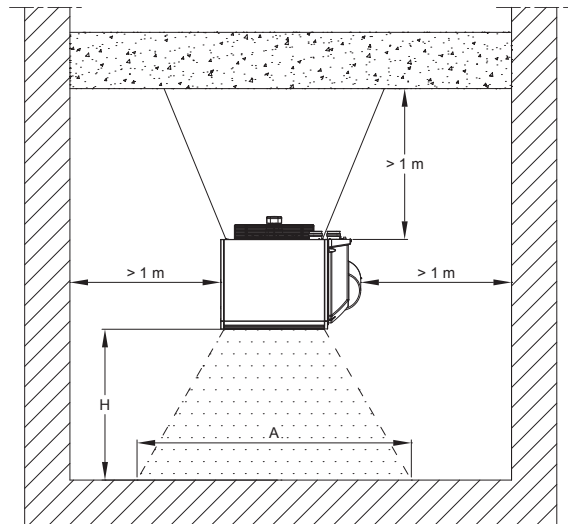

- A Air jet range
- H Gas unit heater installation height

Table 2.1 Installation height and air jet range for vertical downflow gas unit heaters

			R30 V	R40 V	R50 V
Hmin	Minimum height	m	3,5	5,0	6,0
Hmax	Maximum height	m	6,0	7,0	8,0
A	Air jet range	m	20-H	22-H	24-H

E.g.: if a R40 V is installed at 6 m from the ground (H = 6), the air jet range value (A) is (22 - 6) = 16 m.