

1 AIR DUCTING

The ductable gas unit heaters allow to transfer the warm air produced in areas even far away from the gas unit heater, using appropriate air ducts.

The models of ductable gas unit heaters available in the Robur gas unit heaters range are:

- ▶ R series: models R30 C, R40 C, R50 C, R80 C.
- ▶ M series: models M20 C, M30 C, M60 C.

The air ducting must be designed and sized taking into account:

- ▶ minimum air flow to be granted to the gas unit heater (air flow at maximum useful head)

- ▶ minimum pressure drop on heat flow delivery
- ▶ maximum useful head of the centrifugal fan

The latter data is useful for the correct sizing of the air duct which must not have pressure losses greater than the fan head. The application of a minimum pressure drop on the heat flow delivery, where necessary, serves to operate the centrifugal fan within its working curve, avoiding excessive electrical absorption of the motor.

All these data are summarized in Table 1.1 p. 1 below.

Table 1.1 Centrifugal gas unit heaters characteristics

			R30 C	R40 C	R50 C	R80 C	M20 C	M30 C	M60 C
Installation data									
Air flow	at maximum available head	m ³ /h	1850	3300	4700	6250	1900	3100	6400
	free blowing	m ³ /h	2900	4000	5500	8000	2800	4000	8000
maximum useful pressure head		Pa	120		240	120	110		
minimum pressure drop on heat flow delivery		Pa	0	50		0	50	30	

For air ducts for medium/large size gas unit heaters, it is recommended to use the constant pressure drop method (tapering of the ducts along the length).



For details of the characteristic curve of centrifugal fans, refer to Section C01.08.

1.1 DUCTING FLANGE

Below are the dimensions of the flange connections for the outlet air ducting of the gas unit heater.

In the case of the R C series gas unit heaters there is no hole for the lateral fixing of the duct, but a slot, which therefore allows greater flexibility in the dimensions of the flange to be connected.

Table 1.2 Flange dimensions for air ducting

				R30 C	R40 C	R50 C	R80 C	M20 C	M30 C	M60 C
Installation data										
Dimensions	Ducting flange	width	mm	528 (1)	722 (2)	1113 (3)	520 (4)	660 (5)	1160 (6)	
		height	mm	520						

- (1) Slots for fixing from 520 to 536 mm wide.
- (2) Slots for fixing from 714 to 730 mm wide.
- (3) Slots for fixing from 1109 to 1121 mm wide.
- (4) Also available 480 mm wide fixing.
- (5) Also available 620 mm wide fixing.
- (6) Also available 1120 mm wide fixing.

1.2 AIR DUCT PRESSURE DROPS

The pressure drops due to air distribution inside the ducts can be divided into:

- ▶ Continuous (or distributed) pressure drops
- ▶ Localized pressure drops

1.2.1 Continuous (or distributed) pressure drops

The continuous pressure drops derive from the friction of the air moved by the fan on the internal walls of the linear air duct and are therefore proportional to the length of the duct travelled by air, assuming that it has a straight linear path.

The continuous pressure drops are variable according to the roughness of the duct considered, which can be classified

according to Table 1.3 p. 1 below.

Table 1.3 Air duct roughness

Material	Roughness class	Roughness
PVC duct Aluminium sheet duct	very smooth	0,03
Galvanized sheet metal duct Stainless steel duct	smooth	0,09
Duct with polyethylene inner lining Duct with fibreglass inner lining Smooth concrete duct	rough	0,90
Flexible metal duct Flexible non-metal duct Unsmoothed concrete duct	very rough	3,00

1.2.1.1 Smooth circular ducts

Below is the diagram with the continuous pressure drops (in Pa/m) for smooth circular ducts, depending on the air flow rate, the diameter of the ducts and the air speed inside them, considering an air temperature of 20 °C and installation altitude of

0 m asl.

These data can be considered valid for air temperatures between 5 and 35 °C and for altitudes between 0 and 500 m asl.

For higher air temperatures the sizing with these data is conservative as the expected pressure drops are lower.

Figure 1.1 Continuous air pressure drops - Smooth circular ducts - T = 20 °C - 0 m asl

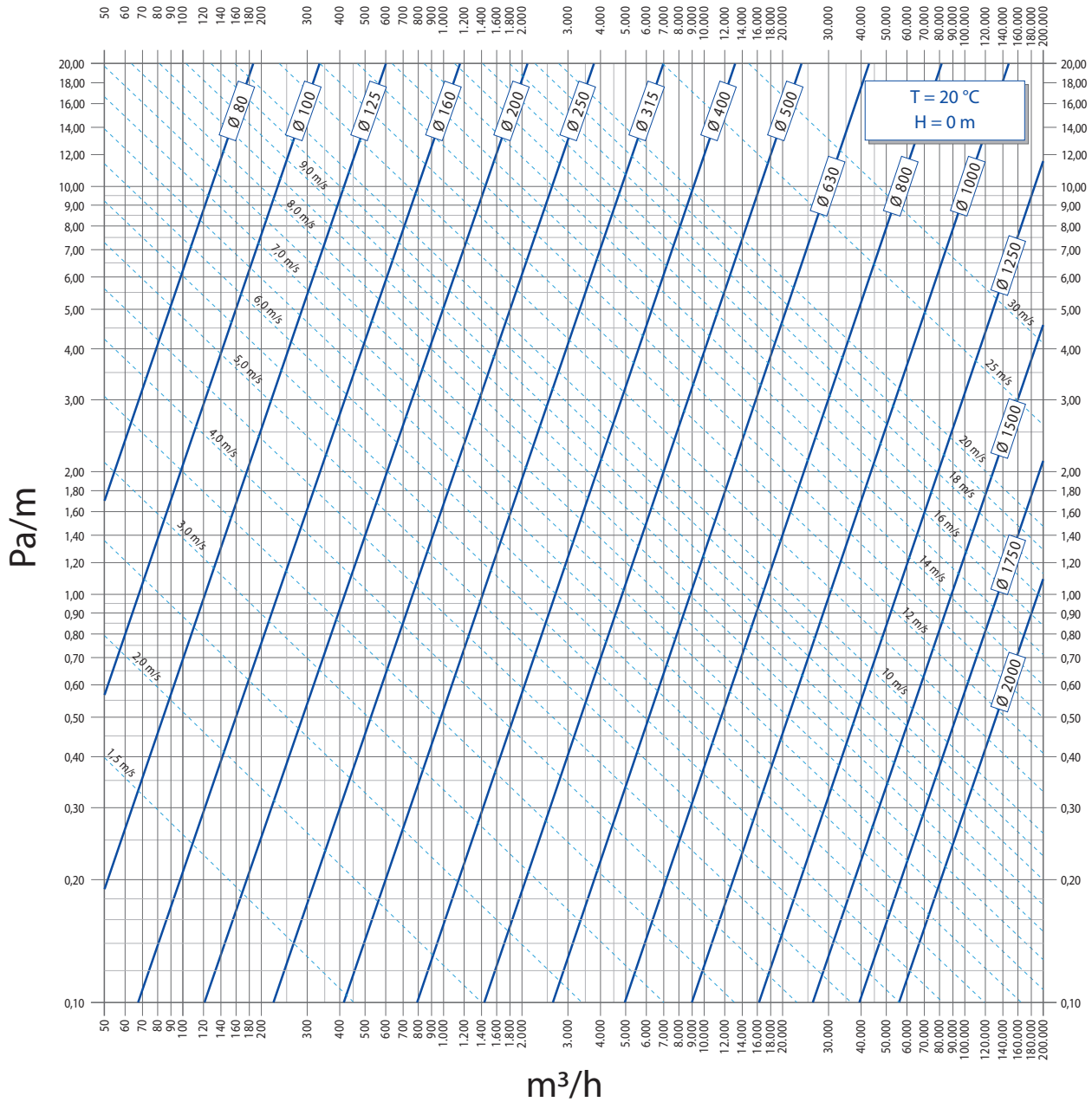

1.2.1.2 Rough circular ducts

Below is the diagram with the continuous pressure drops (in Pa/m) for rough circular ducts, depending on the air flow rate, the diameter of the ducts and the air speed inside them, considering an air temperature of 20 °C and installation altitude of

0 m asl.

These data can be considered valid for air temperatures between 5 and 35 °C and for altitudes between 0 and 500 m asl.

For higher air temperatures the sizing with these data is conservative as the expected pressure drops are lower.

Figure 1.2 Continuous air pressure drops - Rough circular ducts - T = 20 °C - 0 m asl

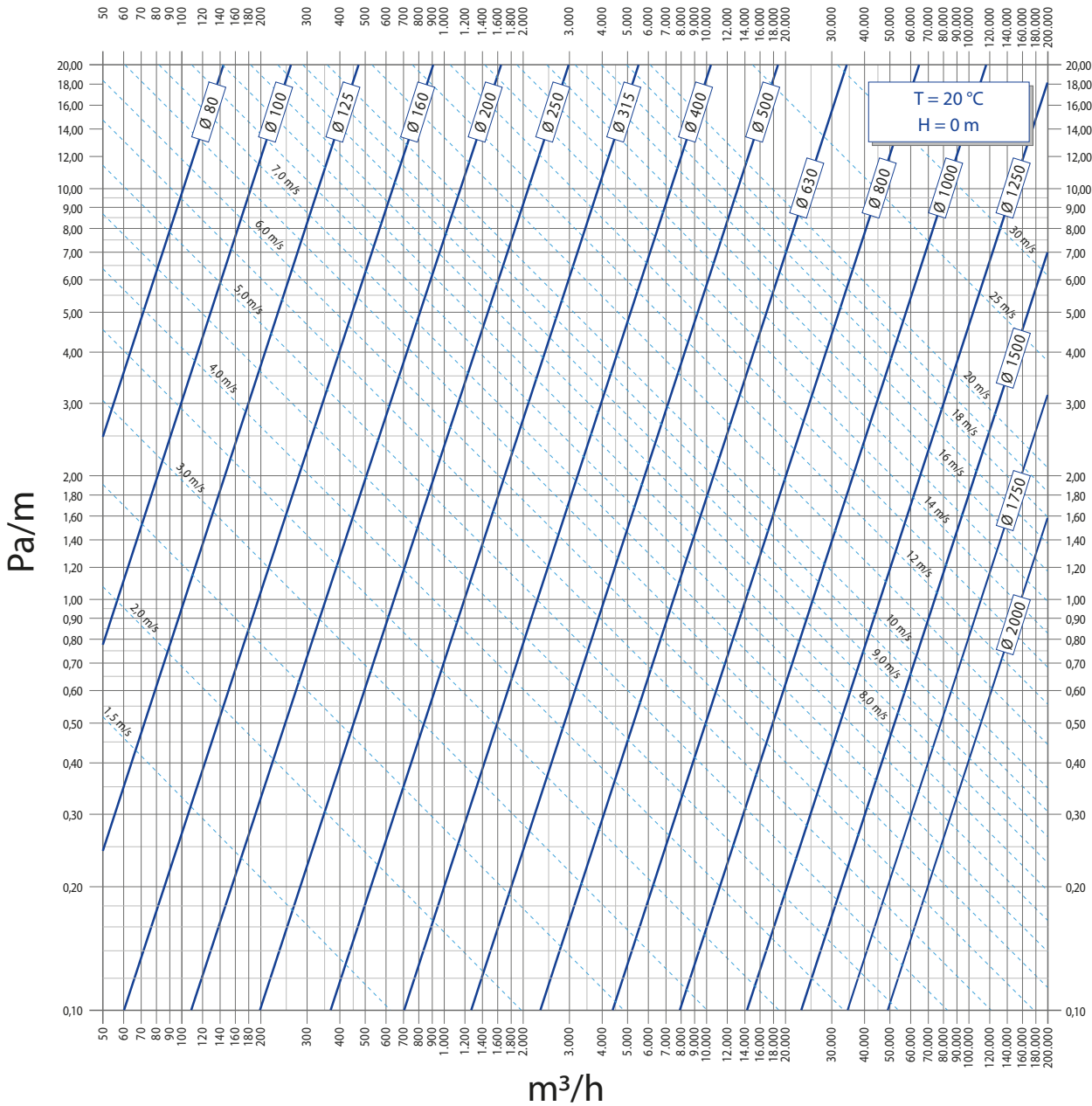

1.2.1.3 Rectangular ducts

For rectangular ducts, the continuous pressure drop can be obtained by transforming the rectangular section into an

equivalent circular section using Table 1.4 p. 4 below, which shows, for each rectangular section of the duct, the diameter and air speed in the equivalent circular duct.

Table 1.4 Rectangular duct equivalent diameters

B	A	100	150	200	250	300	350	400	450	500	550	600	650	700	750	800
100	\varnothing_e	109	133	152	169	183	195	207	217	227	236	245	253	261	268	275
	f	0,94	0,93	0,91	0,89	0,87	0,86	0,84	0,82	0,81	0,80	0,79	0,77	0,76	0,75	0,74
150	\varnothing_e	133	164	189	210	229	245	260	274	287	299	310	321	331	341	350
	f	0,93	0,94	0,93	0,92	0,91	0,90	0,89	0,87	0,86	0,85	0,84	0,83	0,82	0,81	0,80
200	\varnothing_e	152	189	219	244	266	286	305	321	337	352	365	378	391	402	414
	f	0,91	0,93	0,94	0,94	0,93	0,92	0,91	0,90	0,89	0,88	0,87	0,86	0,86	0,85	0,84
250	\varnothing_e	169	210	244	273	299	322	343	363	381	398	414	429	443	457	470
	f	0,89	0,92	0,94	0,94	0,94	0,93	0,93	0,92	0,91	0,90	0,90	0,89	0,88	0,87	0,87
300	\varnothing_e	183	229	266	299	328	354	378	400	420	439	457	474	490	506	520
	f	0,87	0,91	0,93	0,94	0,94	0,94	0,93	0,93	0,92	0,92	0,91	0,90	0,90	0,89	0,89
350	\varnothing_e	195	245	286	322	354	383	409	433	455	477	496	515	533	550	567
	f	0,86	0,90	0,92	0,93	0,94	0,94	0,94	0,93	0,93	0,93	0,92	0,92	0,91	0,91	0,90
400	\varnothing_e	207	260	305	343	378	409	437	464	488	511	533	553	573	592	609
	f	0,84	0,89	0,91	0,93	0,93	0,94	0,94	0,94	0,94	0,93	0,93	0,92	0,92	0,92	0,91
450	\varnothing_e	217	274	321	363	400	433	464	492	518	543	567	589	610	630	649
	f	0,82	0,87	0,90	0,92	0,93	0,93	0,94	0,94	0,94	0,94	0,93	0,93	0,93	0,92	0,92
500	\varnothing_e	227	287	337	381	420	455	488	518	547	573	598	622	644	666	687
	f	0,81	0,86	0,89	0,91	0,92	0,93	0,94	0,94	0,94	0,94	0,94	0,93	0,93	0,93	0,93
550	\varnothing_e	236	299	352	398	439	477	511	543	573	601	628	653	677	700	722
	f	0,80	0,85	0,88	0,90	0,92	0,93	0,93	0,94	0,94	0,94	0,94	0,94	0,94	0,93	0,93
600	\varnothing_e	245	310	365	414	457	496	533	567	598	628	656	683	708	732	755
	f	0,79	0,84	0,87	0,90	0,91	0,92	0,93	0,93	0,94	0,94	0,94	0,94	0,94	0,94	0,93
650	\varnothing_e	253	321	378	429	474	515	553	589	622	653	683	711	737	763	787
	f	0,77	0,83	0,86	0,89	0,90	0,92	0,92	0,93	0,93	0,94	0,94	0,94	0,94	0,94	0,94
700	\varnothing_e	261	331	391	443	490	533	573	610	644	677	708	737	765	792	818
	f	0,76	0,82	0,86	0,88	0,90	0,91	0,92	0,93	0,93	0,94	0,94	0,94	0,94	0,94	0,94
750	\varnothing_e	268	341	402	457	506	550	592	630	666	700	732	763	792	820	847
	f	0,75	0,81	0,85	0,87	0,89	0,91	0,92	0,92	0,93	0,93	0,94	0,94	0,94	0,94	0,94
800	\varnothing_e	275	350	414	470	520	567	609	649	687	722	755	787	818	847	875
	f	0,74	0,80	0,84	0,87	0,89	0,90	0,91	0,92	0,93	0,93	0,93	0,94	0,94	0,94	0,94
850	\varnothing_e	282	359	424	482	534	582	626	668	706	743	778	811	842	872	901
	f	0,74	0,79	0,83	0,86	0,88	0,89	0,91	0,92	0,92	0,93	0,93	0,93	0,94	0,94	0,94
900	\varnothing_e	289	367	435	494	548	597	643	686	726	763	799	833	866	897	927
	f	0,73	0,79	0,82	0,85	0,87	0,89	0,90	0,91	0,92	0,92	0,93	0,93	0,93	0,94	0,94
950	\varnothing_e	295	376	445	506	561	612	659	703	744	783	820	855	889	921	952
	f	0,72	0,78	0,82	0,85	0,87	0,88	0,90	0,91	0,92	0,92	0,93	0,93	0,93	0,94	0,94
1000	\varnothing_e	301	384	454	517	574	626	674	719	762	802	840	876	911	944	976
	f	0,71	0,77	0,81	0,84	0,86	0,88	0,89	0,90	0,91	0,92	0,92	0,93	0,93	0,93	0,94
1100	\varnothing_e	313	399	473	538	598	652	703	751	795	838	878	916	953	988	1022
	f	0,70	0,76	0,80	0,83	0,85	0,87	0,88	0,89	0,90	0,91	0,92	0,92	0,93	0,93	0,93
1200	\varnothing_e	324	413	490	558	620	677	731	780	827	872	914	954	993	1030	1066
	f	0,69	0,74	0,79	0,82	0,84	0,86	0,87	0,89	0,90	0,90	0,91	0,92	0,92	0,93	0,93
1300	\varnothing_e	334	426	506	577	642	701	757	808	857	904	948	990	1031	1069	1107
	f	0,67	0,73	0,77	0,80	0,83	0,85	0,86	0,88	0,89	0,90	0,90	0,91	0,92	0,92	0,92
1400	\varnothing_e	344	439	522	595	662	724	781	835	886	934	980	1024	1066	1107	1146
	f	0,66	0,72	0,76	0,79	0,82	0,84	0,86	0,87	0,88	0,89	0,90	0,91	0,91	0,92	0,92
1500	\varnothing_e	353	452	536	612	681	745	805	860	913	963	1011	1057	1100	1143	1183
	f	0,65	0,71	0,75	0,79	0,81	0,83	0,85	0,86	0,87	0,88	0,89	0,90	0,91	0,91	0,92
1600	\varnothing_e	362	463	551	629	700	766	827	885	939	991	1041	1088	1133	1177	1219
	f	0,64	0,70	0,74	0,78	0,80	0,82	0,84	0,85	0,87	0,88	0,89	0,89	0,90	0,91	0,91
1700	\varnothing_e	371	475	564	644	718	785	849	908	964	1018	1069	1118	1164	1209	1253
	f	0,64	0,69	0,74	0,77	0,79	0,81	0,83	0,85	0,86	0,87	0,88	0,89	0,89	0,90	0,91
1800	\varnothing_e	379	485	577	660	735	804	869	930	988	1043	1096	1146	1195	1241	1286
	f	0,63	0,69	0,73	0,76	0,79	0,81	0,82	0,84	0,85	0,86	0,87	0,88	0,89	0,90	0,90
1900	\varnothing_e	387	496	590	674	751	823	889	952	1012	1068	1122	1174	1224	1271	1318
	f	0,62	0,68	0,72	0,75	0,78	0,80	0,82	0,83	0,85	0,86	0,87	0,88	0,88	0,89	0,90
2000	\varnothing_e	395	506	602	688	767	840	908	973	1034	1092	1147	1200	1252	1301	1348
	f	0,61	0,67	0,71	0,74	0,77	0,79	0,80	0,83	0,84	0,85	0,86	0,87	0,88	0,89	0,89
2200	\varnothing_e	410	525	625	715	797	874	945	1013	1076	1137	1195	1251	1305	1356	1406
	f	0,60	0,66	0,70	0,73	0,76	0,78	0,80	0,81	0,83	0,84	0,85	0,86	0,87	0,88	0,88

B	A	850	900	950	1000	1100	1200	1300	1400	1500	1600	1700	1800	1900	2000	2200
850	Ø _e	929	956	982	1007	1055	1100	1143	1183	1222	1259	1295	1329	1362	1394	1455
	f	0,94	0,94	0,94	0,94	0,93	0,93	0,93	0,92	0,92	0,92	0,91	0,91	0,90	0,90	0,89
900	Ø _e	956	984	1011	1037	1086	1133	1177	1220	1260	1298	1335	1371	1405	1438	1501
	f	0,94	0,94	0,94	0,94	0,94	0,93	0,93	0,93	0,92	0,92	0,91	0,91	0,90	0,90	0,89
950	Ø _e	982	1011	1039	1065	1117	1165	1211	1255	1297	1336	1375	1412	1447	1482	1547
	f	0,94	0,94	0,94	0,94	0,94	0,94	0,93	0,93	0,93	0,92	0,92	0,92	0,91	0,91	0,90
1000	Ø _e	1007	1037	1065	1093	1146	1196	1244	1289	1332	1373	1413	1451	1488	1523	1591
	f	0,94	0,94	0,94	0,94	0,94	0,94	0,93	0,93	0,93	0,93	0,92	0,92	0,92	0,91	0,90
1100	Ø _e	1055	1086	1117	1146	1202	1256	1306	1354	1400	1444	1486	1527	1566	1604	1676
	f	0,93	0,94	0,94	0,94	0,94	0,94	0,94	0,94	0,93	0,93	0,93	0,92	0,92	0,92	0,91
1200	Ø _e	1100	1133	1165	1196	1256	1312	1365	1416	1464	1511	1555	1598	1640	1680	1756
	f	0,93	0,93	0,94	0,94	0,94	0,94	0,94	0,94	0,94	0,93	0,93	0,93	0,93	0,92	0,92
1300	Ø _e	1143	1177	1211	1244	1306	1365	1421	1475	1526	1574	1621	1667	1710	1753	1833
	f	0,93	0,93	0,93	0,93	0,94	0,94	0,94	0,94	0,94	0,94	0,93	0,93	0,93	0,93	0,92
1400	Ø _e	1183	1220	1255	1289	1354	1416	1475	1530	1584	1635	1684	1732	1778	1822	1906
	f	0,92	0,93	0,93	0,93	0,94	0,94	0,94	0,94	0,94	0,94	0,94	0,93	0,93	0,93	0,93
1500	Ø _e	1222	1260	1297	1332	1400	1464	1526	1584	1640	1693	1745	1794	1842	1889	1977
	f	0,92	0,92	0,93	0,93	0,93	0,94	0,94	0,94	0,94	0,94	0,94	0,94	0,94	0,93	0,93
1600	Ø _e	1259	1298	1336	1373	1444	1511	1574	1635	1693	1749	1803	1854	1904	1952	2044
	f	0,92	0,92	0,92	0,93	0,93	0,93	0,94	0,94	0,94	0,94	0,94	0,94	0,94	0,94	0,93
1700	Ø _e	1295	1335	1375	1413	1486	1555	1621	1684	1745	1803	1858	1912	1964	2014	2110
	f	0,91	0,92	0,92	0,92	0,93	0,93	0,93	0,94	0,94	0,94	0,94	0,94	0,94	0,94	0,93
1800	Ø _e	1329	1371	1412	1451	1527	1598	1667	1732	1794	1854	1912	1968	2021	2073	2173
	f	0,91	0,91	0,92	0,92	0,92	0,93	0,93	0,93	0,94	0,94	0,94	0,94	0,94	0,94	0,94
1900	Ø _e	1362	1405	1447	1488	1566	1640	1710	1778	1842	1904	1964	2021	2077	2131	2233
	f	0,90	0,91	0,91	0,92	0,92	0,93	0,93	0,93	0,94	0,94	0,94	0,94	0,94	0,94	0,94
2000	Ø _e	1394	1438	1482	1523	1604	1680	1753	1822	1889	1952	2014	2073	2131	2186	2292
	f	0,90	0,90	0,91	0,91	0,92	0,92	0,93	0,93	0,93	0,94	0,94	0,94	0,94	0,94	0,94
2200	Ø _e	1455	1501	1547	1591	1676	1756	1833	1906	1977	2044	2110	2173	2233	2292	2405
	f	0,89	0,89	0,90	0,90	0,91	0,92	0,92	0,93	0,93	0,93	0,93	0,94	0,94	0,94	0,94

A Rectangular duct height
 B Rectangular duct width
 Ø_e Equivalent circular diameter
 f Speed correction factor

The following formula shall be used to calculate the speed in the equivalent circular duct:

$$v = v_e \cdot f$$

where:

- v Speed in the rectangular duct [m/s]
- v_e Equivalent speed in the circular duct [m/s]
- f Speed correction factor (Table 1.4 p. 4)

Figure 1.3 Air duct diameter conversion

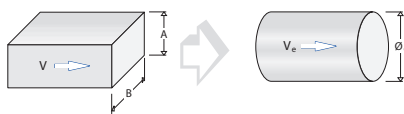

A Rectangular duct height
 B Rectangular duct width
 v Speed in the rectangular duct
 v_e Equivalent speed in the circular duct

1.2.2 Localized pressure drops

Localised pressure drops are associated with the presence of non-straight elements in the plant, such as elbows, inlets, emission terminals.

Localised pressure drops are normally much more significant than continuous pressure drops, especially with regard to emission terminals. However, the latter are not dealt with in this paragraph as it is impossible to generalise them.

Below is a simplified calculation system for some simpler duct geometries, leaving specific literature (typically made available by manufacturers) more information on geometries not considered here and terminals.

The simplified calculation method involves determining the localized pressure drop coefficients ξ, a function of the geometric characteristics of the elements, detailed in the following paragraphs (Paragraph 1.2.2.1 p. 5 for circular section ducts and Paragraph 1.2.2.2 p. 6 for rectangular section ducts).

Then all the coefficients ξ for the most unfavourable duct section are added together and on the basis of the resulting total the localized pressure drop is determined as a function of the air speed in the duct (Paragraph 1.2.2.3 p. 7).

1.2.2.1 Circular ducts

Table 1.5 Coefficients ξ for the calculation of localized pressure drops in circular ducts

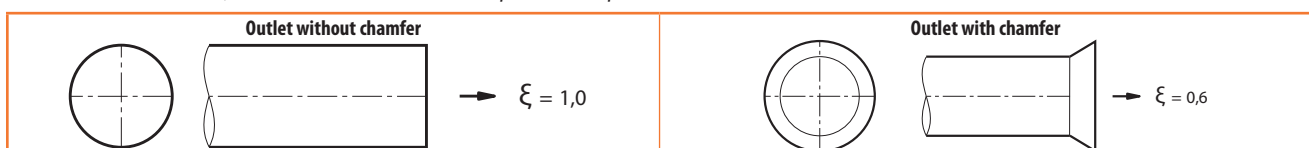

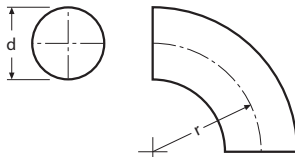
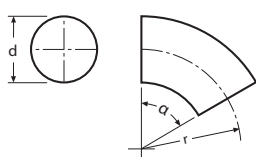
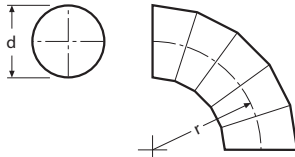
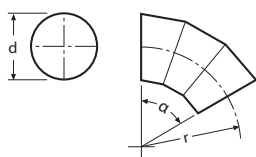
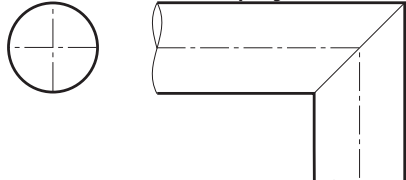
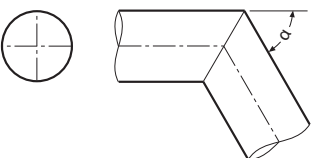
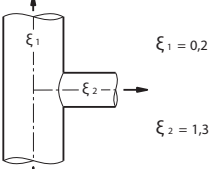
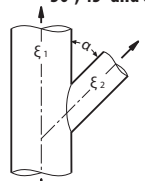
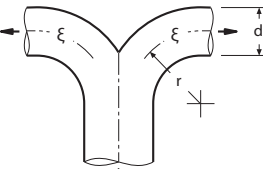
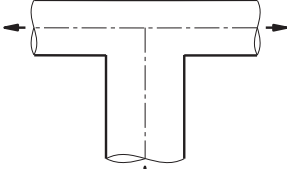
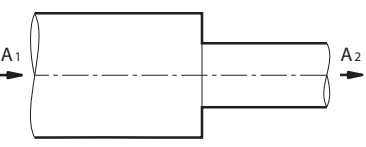
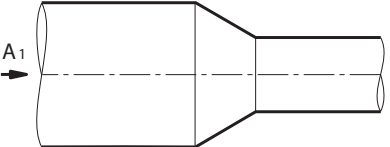
<p>90° elbow</p>  <table border="1" data-bbox="598 212 702 403"> <thead> <tr> <th>r/d</th> <th>ξ</th> </tr> </thead> <tbody> <tr><td>0,50</td><td>0,9</td></tr> <tr><td>0,75</td><td>0,5</td></tr> <tr><td>1,00</td><td>0,4</td></tr> <tr><td>1,50</td><td>0,3</td></tr> <tr><td>2,00</td><td>0,2</td></tr> </tbody> </table>	r/d	ξ	0,50	0,9	0,75	0,5	1,00	0,4	1,50	0,3	2,00	0,2	<p>30°, 45° and 60° elbow</p>  <table border="1" data-bbox="1173 212 1404 403"> <thead> <tr> <th rowspan="2">r/d</th> <th colspan="3">ξ</th> </tr> <tr> <th>$\alpha = 30^\circ$</th> <th>$\alpha = 45^\circ$</th> <th>$\alpha = 60^\circ$</th> </tr> </thead> <tbody> <tr><td>0,50</td><td>0,3</td><td>0,5</td><td>0,7</td></tr> <tr><td>0,75</td><td>0,2</td><td>0,3</td><td>0,3</td></tr> <tr><td>1,00</td><td>0,1</td><td>0,2</td><td>0,3</td></tr> <tr><td>1,50</td><td>0,1</td><td>0,2</td><td>0,2</td></tr> <tr><td>2,00</td><td>0,1</td><td>0,1</td><td>0,1</td></tr> </tbody> </table>	r/d	ξ			$\alpha = 30^\circ$	$\alpha = 45^\circ$	$\alpha = 60^\circ$	0,50	0,3	0,5	0,7	0,75	0,2	0,3	0,3	1,00	0,1	0,2	0,3	1,50	0,1	0,2	0,2	2,00	0,1	0,1	0,1
r/d	ξ																																							
0,50	0,9																																							
0,75	0,5																																							
1,00	0,4																																							
1,50	0,3																																							
2,00	0,2																																							
r/d	ξ																																							
	$\alpha = 30^\circ$	$\alpha = 45^\circ$	$\alpha = 60^\circ$																																					
0,50	0,3	0,5	0,7																																					
0,75	0,2	0,3	0,3																																					
1,00	0,1	0,2	0,3																																					
1,50	0,1	0,2	0,2																																					
2,00	0,1	0,1	0,1																																					
<p>90° sector elbow</p>  <table border="1" data-bbox="598 436 702 627"> <thead> <tr> <th>r/d</th> <th>ξ</th> </tr> </thead> <tbody> <tr><td>0,50</td><td>1,1</td></tr> <tr><td>0,75</td><td>0,6</td></tr> <tr><td>1,00</td><td>0,4</td></tr> <tr><td>1,50</td><td>0,3</td></tr> <tr><td>2,00</td><td>0,2</td></tr> </tbody> </table>	r/d	ξ	0,50	1,1	0,75	0,6	1,00	0,4	1,50	0,3	2,00	0,2	<p>30°, 45° and 60° sector elbow</p>  <table border="1" data-bbox="1173 436 1404 627"> <thead> <tr> <th rowspan="2">r/d</th> <th colspan="3">ξ</th> </tr> <tr> <th>$\alpha = 30^\circ$</th> <th>$\alpha = 45^\circ$</th> <th>$\alpha = 60^\circ$</th> </tr> </thead> <tbody> <tr><td>0,50</td><td>0,4</td><td>0,6</td><td>0,7</td></tr> <tr><td>0,75</td><td>0,2</td><td>0,3</td><td>0,4</td></tr> <tr><td>1,00</td><td>0,1</td><td>0,2</td><td>0,3</td></tr> <tr><td>1,50</td><td>0,1</td><td>0,2</td><td>0,2</td></tr> <tr><td>2,00</td><td>0,1</td><td>0,1</td><td>0,1</td></tr> </tbody> </table>	r/d	ξ			$\alpha = 30^\circ$	$\alpha = 45^\circ$	$\alpha = 60^\circ$	0,50	0,4	0,6	0,7	0,75	0,2	0,3	0,4	1,00	0,1	0,2	0,3	1,50	0,1	0,2	0,2	2,00	0,1	0,1	0,1
r/d	ξ																																							
0,50	1,1																																							
0,75	0,6																																							
1,00	0,4																																							
1,50	0,3																																							
2,00	0,2																																							
r/d	ξ																																							
	$\alpha = 30^\circ$	$\alpha = 45^\circ$	$\alpha = 60^\circ$																																					
0,50	0,4	0,6	0,7																																					
0,75	0,2	0,3	0,4																																					
1,00	0,1	0,2	0,3																																					
1,50	0,1	0,2	0,2																																					
2,00	0,1	0,1	0,1																																					
<p>90° sharp-edged elbow</p>  <p>$\xi = 1,4$</p>	<p>30°, 45° and 60° sharp-edged elbow</p>  <table border="1" data-bbox="1220 683 1404 772"> <thead> <tr> <th colspan="3">ξ</th> </tr> <tr> <th>$\alpha = 30^\circ$</th> <th>$\alpha = 45^\circ$</th> <th>$\alpha = 60^\circ$</th> </tr> </thead> <tbody> <tr> <td>0,4</td> <td>0,7</td> <td>1,0</td> </tr> </tbody> </table>	ξ			$\alpha = 30^\circ$	$\alpha = 45^\circ$	$\alpha = 60^\circ$	0,4	0,7	1,0																														
ξ																																								
$\alpha = 30^\circ$	$\alpha = 45^\circ$	$\alpha = 60^\circ$																																						
0,4	0,7	1,0																																						
<p>Simple branch with 90° tee</p>  <p>$\xi_1 = 0,2$ $\xi_2 = 1,3$</p>	<p>30°, 45° and 60° simple branch</p>  <table border="1" data-bbox="1133 952 1284 1030"> <thead> <tr> <th colspan="3">ξ_2</th> </tr> <tr> <th>$\alpha = 30^\circ$</th> <th>$\alpha = 45^\circ$</th> <th>$\alpha = 60^\circ$</th> </tr> </thead> <tbody> <tr> <td>0,4</td> <td>0,7</td> <td>0,9</td> </tr> </tbody> </table>	ξ_2			$\alpha = 30^\circ$	$\alpha = 45^\circ$	$\alpha = 60^\circ$	0,4	0,7	0,9																														
ξ_2																																								
$\alpha = 30^\circ$	$\alpha = 45^\circ$	$\alpha = 60^\circ$																																						
0,4	0,7	0,9																																						
<p>Filletted branch</p>  <table border="1" data-bbox="582 1086 686 1265"> <thead> <tr> <th>r/d</th> <th>ξ</th> </tr> </thead> <tbody> <tr><td>0,50</td><td>1,2</td></tr> <tr><td>0,75</td><td>0,6</td></tr> <tr><td>1,00</td><td>0,4</td></tr> <tr><td>1,50</td><td>0,3</td></tr> <tr><td>2,00</td><td>0,2</td></tr> </tbody> </table>	r/d	ξ	0,50	1,2	0,75	0,6	1,00	0,4	1,50	0,3	2,00	0,2	<p>Double branch with 90° tee</p>  <p>$\xi_1 = 1,4$</p>																											
r/d	ξ																																							
0,50	1,2																																							
0,75	0,6																																							
1,00	0,4																																							
1,50	0,3																																							
2,00	0,2																																							
<p>Narrowing without chamfer</p>  <table border="1" data-bbox="614 1310 742 1489"> <thead> <tr> <th>A_2/A_1</th> <th>ξ</th> </tr> </thead> <tbody> <tr><td>0,2</td><td>0,5</td></tr> <tr><td>0,4</td><td>0,4</td></tr> <tr><td>0,6</td><td>0,3</td></tr> <tr><td>0,8</td><td>0,2</td></tr> </tbody> </table>	A_2/A_1	ξ	0,2	0,5	0,4	0,4	0,6	0,3	0,8	0,2	<p>Narrowing with chamfer</p>  <p>$\xi = 0,2$</p>																													
A_2/A_1	ξ																																							
0,2	0,5																																							
0,4	0,4																																							
0,6	0,3																																							
0,8	0,2																																							

1.2.2.2 Rectangular ducts

Table 1.6 Coefficients ξ for the calculation of localized pressure drops in circular ducts

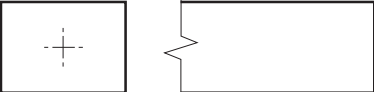
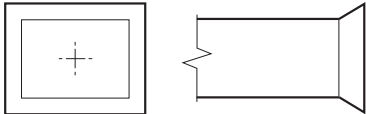
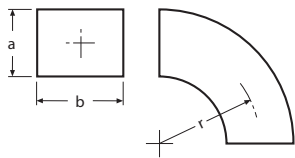
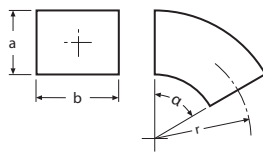
<p>Outlet without chamfer</p>  <p>$\xi = 1,20$</p>	<p>Outlet with chamfer</p>  <p>$\xi = 0,8$</p>																									
<p>90° elbow</p>  <table border="1" data-bbox="550 1803 742 1960"> <thead> <tr> <th rowspan="2">r/a</th> <th colspan="2">ξ</th> </tr> <tr> <th>b/a ≤ 1</th> <th>b/a ≥ 1</th> </tr> </thead> <tbody> <tr><td>0,50</td><td>1,2</td><td>1,0</td></tr> <tr><td>0,75</td><td>0,6</td><td>0,4</td></tr> <tr><td>1,00</td><td>0,3</td><td>0,2</td></tr> <tr><td>1,50</td><td>0,1</td><td>0,1</td></tr> </tbody> </table>	r/a	ξ		b/a ≤ 1	b/a ≥ 1	0,50	1,2	1,0	0,75	0,6	0,4	1,00	0,3	0,2	1,50	0,1	0,1	<p>30°, 45° and 60° elbow</p>  <table border="1" data-bbox="1181 1825 1404 1948"> <thead> <tr> <th colspan="2">ξ</th> </tr> </thead> <tbody> <tr> <td>$\alpha = 30^\circ$</td> <td>$\xi = \xi_{(90^\circ)} \cdot 0,33$</td> </tr> <tr> <td>$\alpha = 45^\circ$</td> <td>$\xi = \xi_{(90^\circ)} \cdot 0,50$</td> </tr> <tr> <td>$\alpha = 60^\circ$</td> <td>$\xi = \xi_{(90^\circ)} \cdot 0,66$</td> </tr> </tbody> </table>	ξ		$\alpha = 30^\circ$	$\xi = \xi_{(90^\circ)} \cdot 0,33$	$\alpha = 45^\circ$	$\xi = \xi_{(90^\circ)} \cdot 0,50$	$\alpha = 60^\circ$	$\xi = \xi_{(90^\circ)} \cdot 0,66$
r/a		ξ																								
	b/a ≤ 1	b/a ≥ 1																								
0,50	1,2	1,0																								
0,75	0,6	0,4																								
1,00	0,3	0,2																								
1,50	0,1	0,1																								
ξ																										
$\alpha = 30^\circ$	$\xi = \xi_{(90^\circ)} \cdot 0,33$																									
$\alpha = 45^\circ$	$\xi = \xi_{(90^\circ)} \cdot 0,50$																									
$\alpha = 60^\circ$	$\xi = \xi_{(90^\circ)} \cdot 0,66$																									

		<p>90° elbow with deflectors</p> <table border="1"> <thead> <tr> <th>a</th> <th>N</th> <th>X₁</th> <th>X₂</th> <th>X₃</th> <th>X₄</th> </tr> </thead> <tbody> <tr> <td>300 ÷ 500</td> <td>1</td> <td>1/3a</td> <td>2/3a</td> <td></td> <td></td> </tr> <tr> <td>500 ÷ 1.000</td> <td>2</td> <td>1/6a</td> <td>1/3a</td> <td>1/2a</td> <td></td> </tr> <tr> <td>> 1.000</td> <td>3</td> <td>1/12a</td> <td>1/6a</td> <td>1/4a</td> <td>1/2a</td> </tr> </tbody> </table>	a	N	X ₁	X ₂	X ₃	X ₄	300 ÷ 500	1	1/3a	2/3a			500 ÷ 1.000	2	1/6a	1/3a	1/2a		> 1.000	3	1/12a	1/6a	1/4a	1/2a	<table border="1"> <thead> <tr> <th>r/a</th> <th>ξ</th> </tr> </thead> <tbody> <tr> <td>0,50</td> <td>0,5</td> </tr> <tr> <td>0,75</td> <td>0,2</td> </tr> <tr> <td>1,00</td> <td>0,1</td> </tr> <tr> <td>1,50</td> <td>0,1</td> </tr> </tbody> </table>	r/a	ξ	0,50	0,5	0,75	0,2	1,00	0,1	1,50	0,1
a	N	X ₁	X ₂	X ₃	X ₄																																
300 ÷ 500	1	1/3a	2/3a																																		
500 ÷ 1.000	2	1/6a	1/3a	1/2a																																	
> 1.000	3	1/12a	1/6a	1/4a	1/2a																																
r/a	ξ																																				
0,50	0,5																																				
0,75	0,2																																				
1,00	0,1																																				
1,50	0,1																																				
<p>90° sharp-edged elbow</p> <p>ξ = 1,4</p>	<p>30°, 45° and 60° sharp-edged elbow</p> <table border="1"> <thead> <tr> <th colspan="3">ξ</th> </tr> <tr> <th>α = 30°</th> <th>α = 45°</th> <th>α = 60°</th> </tr> </thead> <tbody> <tr> <td>0,5</td> <td>0,7</td> <td>0,9</td> </tr> </tbody> </table>			ξ			α = 30°	α = 45°	α = 60°	0,5	0,7	0,9																									
ξ																																					
α = 30°	α = 45°	α = 60°																																			
0,5	0,7	0,9																																			
<p>90° elbow with normal fins</p> <p>ξ = 0,4</p>	<p>90° elbow with aerodynamic fins</p> <p>ξ = 0,2</p>																																				
<p>Simple branch with 90° tee</p> <p>ξ₁ = 0,2 ξ₂ = 1,3</p>	<p>30°, 45° and 60° simple branch</p> <p>ξ₁ = 0,2</p> <table border="1"> <thead> <tr> <th colspan="3">ξ₂</th> </tr> <tr> <th>α = 30°</th> <th>α = 45°</th> <th>α = 60°</th> </tr> </thead> <tbody> <tr> <td>0,4</td> <td>0,7</td> <td>0,9</td> </tr> </tbody> </table>			ξ ₂			α = 30°	α = 45°	α = 60°	0,4	0,7	0,9																									
ξ ₂																																					
α = 30°	α = 45°	α = 60°																																			
0,4	0,7	0,9																																			
<p>Filleted branch</p> <table border="1"> <thead> <tr> <th>r/a</th> <th>ξ</th> </tr> </thead> <tbody> <tr> <td>0,50</td> <td>1,0</td> </tr> <tr> <td>0,75</td> <td>0,5</td> </tr> <tr> <td>1,00</td> <td>0,3</td> </tr> <tr> <td>1,50</td> <td>0,1</td> </tr> <tr> <td>2,00</td> <td>0,1</td> </tr> </tbody> </table>	r/a	ξ	0,50	1,0	0,75	0,5	1,00	0,3	1,50	0,1	2,00	0,1	<p>Double branch with 90° tee</p> <p>ξ₁ = 1,4</p>																								
r/a	ξ																																				
0,50	1,0																																				
0,75	0,5																																				
1,00	0,3																																				
1,50	0,1																																				
2,00	0,1																																				
<p>Narrowing without chamfer</p> <table border="1"> <thead> <tr> <th>A₂/A₁</th> <th>ξ</th> </tr> </thead> <tbody> <tr> <td>0,2</td> <td>0,5</td> </tr> <tr> <td>0,4</td> <td>0,4</td> </tr> <tr> <td>0,6</td> <td>0,3</td> </tr> <tr> <td>0,8</td> <td>0,2</td> </tr> </tbody> </table>	A ₂ /A ₁	ξ	0,2	0,5	0,4	0,4	0,6	0,3	0,8	0,2	<p>Narrowing with chamfer</p> <p>ξ = 0,2</p>																										
A ₂ /A ₁	ξ																																				
0,2	0,5																																				
0,4	0,4																																				
0,6	0,3																																				
0,8	0,2																																				

1.2.2.3 Calculation of localized pressure drops

To determine the value in Pa of the localized pressure drops, proceed as follows:

- The most unfavourable duct section (the one with the highest pressure drop) is considered.
- Add up all the coefficients ξ for the non-straight elements.
- As a function of the air velocity in the duct, using the Table 1.7 p. 7 below, the value in Pa of the localized pressure drop is determined.

- Add to this value the pressure drops associated with other components that may not be considered and, above all, the pressure drops associated with the emission terminals, always considering the most unfavourable section of the duct.



The air velocity in the duct to be considered to determine the value of the localised pressure drop is the actual air velocity and not that which corresponds to the equivalent circular diameter.

Table 1.7 Calculation of localized pressure drops in Pa for Σξ = 1 ÷ 10 - T = 20 °C - 0 m asl

v	Σξ	1	2	3	4	5	6	7	8	9	10
1,0	z	0,6	1,2	1,8	2,5	3,1	3,7	4,3	4,9	5,5	6,1
1,5	z	1,4	2,8	4,1	5,5	6,9	8,3	9,7	11,0	12,4	13,8
2,0	z	2,5	4,9	7,4	9,8	12,3	14,7	17,2	19,6	22,1	24,5
2,5	z	3,8	7,7	11,5	15,3	19,2	23,0	26,8	30,7	34,5	38,3
3,0	z	5,5	11,0	16,6	22,1	27,6	33,1	38,6	44,1	49,7	55,2
3,2	z	6,3	12,6	18,8	25,1	31,4	37,7	44,0	50,2	56,5	62,8
3,4	z	7,1	14,2	21,3	28,4	35,4	42,5	49,6	56,7	63,8	70,9
3,6	z	7,9	15,9	23,8	31,8	39,7	47,7	55,6	63,6	71,5	79,5

v	Σξ	1	2	3	4	5	6	7	8	9	10
3,8	z	8,9	17,7	26,6	35,4	44,3	53,1	62,0	70,8	79,7	88,5
4,0	z	9,8	19,6	29,4	39,2	49,1	58,9	68,7	78,5	88,3	98,1
4,2	z	10,8	21,6	32,4	43,3	54,1	64,9	75,7	86,5	97,3	108,0
4,4	z	11,9	23,7	35,6	47,5	59,4	71,2	83,1	95,0	107,0	119,0
4,6	z	13,0	25,9	38,9	51,9	64,9	77,8	90,8	104,0	117,0	130,0
4,8	z	14,1	28,3	42,4	56,5	70,6	84,8	98,9	113,0	127,0	141,0
5,0	z	15,3	30,7	46,0	61,3	76,6	92,0	107,0	123,0	138,0	153,0
5,2	z	16,6	33,2	49,7	66,3	82,9	99,5	116,0	133,0	149,0	166,0
5,4	z	17,9	35,8	53,6	71,5	89,4	107,0	125,0	143,0	161,0	179,0
5,6	z	19,2	38,5	57,7	76,9	96,1	115,0	135,0	154,0	173,0	192,0
5,8	z	20,6	41,3	61,9	82,5	103,0	124,0	144,0	165,0	186,0	206,0
6,0	z	22,1	44,1	66,2	88,3	110,0	132,0	155,0	177,0	199,0	221,0
6,2	z	23,6	47,1	70,7	94,3	118,0	141,0	165,0	189,0	212,0	236,0
6,4	z	25,1	50,2	75,3	100,0	126,0	151,0	176,0	201,0	226,0	251,0
6,6	z	26,7	53,4	80,1	107,0	134,0	160,0	187,0	214,0	240,0	267,0
6,8	z	28,4	56,7	85,1	113,0	142,0	170,0	198,0	227,0	255,0	284,0
7,0	z	30,0	60,1	90,1	120,0	150,0	180,0	210,0	240,0	270,0	300,0
7,2	z	31,8	63,6	95,4	127,0	159,0	191,0	223,0	254,0	286,0	318,0
7,4	z	33,6	67,2	101,0	134,0	168,0	201,0	235,0	269,0	302,0	336,0
7,6	z	35,4	70,8	106,0	142,0	177,0	212,0	248,0	283,0	319,0	354,0
7,8	z	37,3	74,6	112,0	149,0	187,0	224,0	261,0	298,0	336,0	373,0
8,0	z	39,2	78,5	118,0	157,0	196,0	235,0	275,0	314,0	353,0	392,0
8,5	z	44,3	88,6	133,0	177,0	222,0	266,0	310,0	354,0	399,0	443,0
9,0	z	49,7	99,3	149,0	199,0	248,0	298,0	348,0	397,0	447,0	497,0
9,5	z	55,3	111,0	166,0	221,0	277,0	332,0	387,0	443,0	498,0	553,0
10,0	z	61,3	123,0	184,0	245,0	307,0	368,0	429,0	491,0	552,0	613,0
10,5	z	67,6	135,0	203,0	270,0	338,0	406,0	473,0	541,0	608,0	676,0
11,0	z	74,2	148,0	223,0	297,0	371,0	445,0	519,0	594,0	668,0	742,0
11,5	z	81,1	162,0	243,0	324,0	405,0	487,0	568,0	649,0	730,0	811,0
12,0	z	88,3	177,0	265,0	353,0	441,0	530,0	618,0	706,0	795,0	883,0
12,5	z	95,8	192,0	287,0	383,0	479,0	575,0	671,0	766,0	862,0	958,0
13,0	z	104,0	207,0	311,0	414,0	518,0	622,0	725,0	829,0	933,0	1040,0
13,5	z	112,0	223,0	335,0	447,0	559,0	670,0	782,0	894,0	1010,0	1120,0
14,0	z	120,0	240,0	361,0	481,0	601,0	721,0	841,0	961,0	1080,0	1200,0
14,5	z	129,0	258,0	387,0	516,0	645,0	773,0	902,0	1030,0	1160,0	1290,0
15,0	z	138,0	276,0	414,0	552,0	690,0	828,0	966,0	1100,0	1240,0	1380,0
15,5	z	147,0	295,0	442,0	589,0	737,0	884,0	1030,0	1180,0	1330,0	1470,0
16,0	z	157,0	314,0	471,0	628,0	785,0	942,0	1100,0	1260,0	1410,0	1570,0

v Speed in the duct

Σξ Sum of localized pressure drop coefficients ξ for the most disadvantaged section

z Localized pressure drops [Pa]

2 ACCESSORIES FOR DUCTING THE AIR INTAKE



The accessories in this section can only be used for M C series gas unit heaters.

The following Figure shows an example of the installation of the accessories available for the ducting of a M C series gas unit heater.

Figure 2.1 Example of installation of M C series gas unit heater with accessories for air ducting

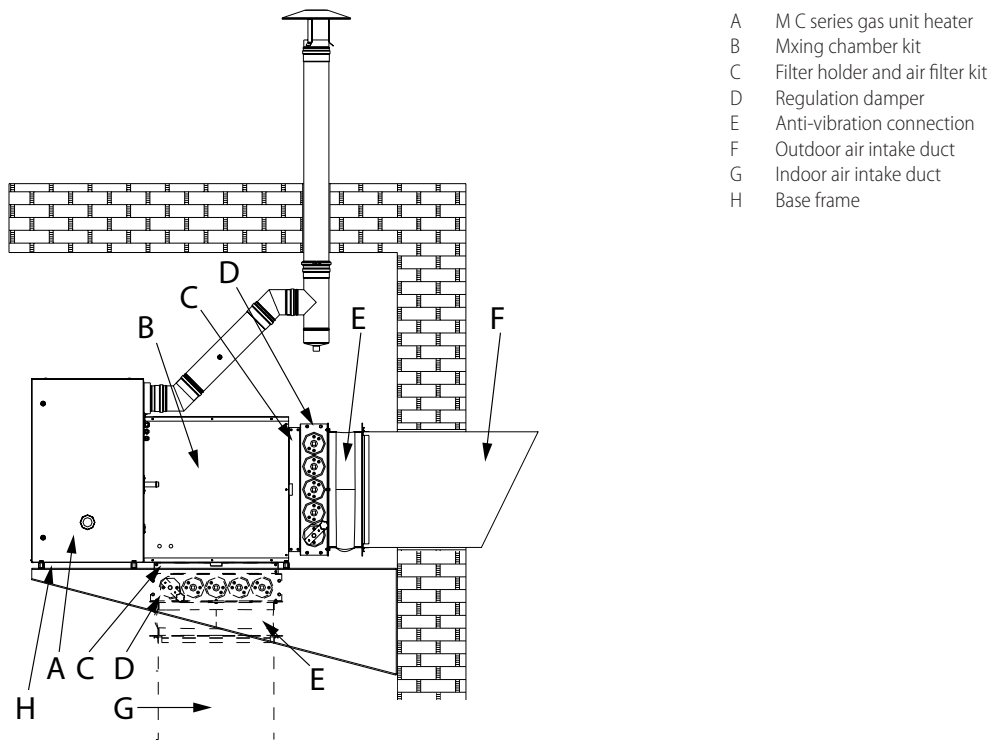

- A M C series gas unit heater
- B Mxing chamber kit
- C Filter holder and air filter kit
- D Regulation damper
- E Anti-vibration connection
- F Outdoor air intake duct
- G Indoor air intake duct
- H Base frame

2.1 MXING CHAMBER KIT

Figure 2.2 Mxing chamber kit

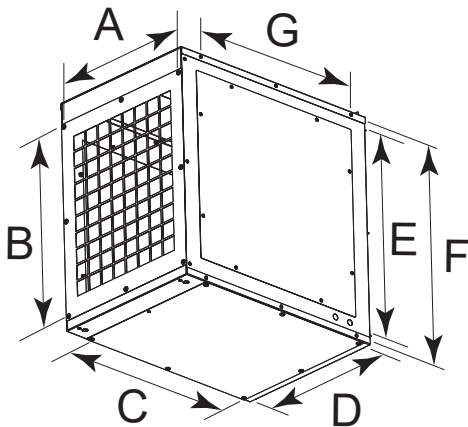

Table 2.1 Mxing chamber kit

Code	Figure	Use	A (1) D (1)	B (1) C (1)	E (1)	F (1)	G (1)
OCSS000	2.2 p. 9	M20 C	420	527	570	615	520
OCSS001		M30 C	520	527	570	615	520
OCSS002		M60 C	1020	527	570	615	520

1. Measures referred to the holes centre distance.

2.2 FILTER HOLDER KIT

Figure 2.3 Filter holder kit

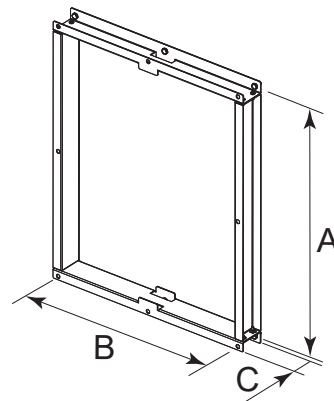

Table 2.2 Filter holder kit

Code	Figure	Use	A (1)	B (1)	C
OSTF014	2.3 p. 9	M20 C	527	420	53
OSTF015		M30 C	527	520	53
OSTF016		M60 C	527	1020	53

1. Measures referred to the holes centre distance.

2.3 AIR FILTER

Figure 2.4 Air filter

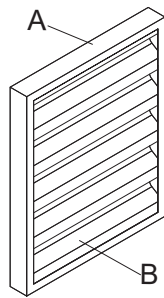

- A Containment frame
- B Pleated synthetic fibre filter cell

Table 2.3 Air filter

Code	Figure	Use	Class
OFLT013	2.4 p. 10	M20 C	G3 (1)
OFLT012		M30 C, M60 C (2)	

- Filters for coarse dust G, classification according to EN 779, corresponding to EU 3 according to Eurovent standards.
- For the model M60 C 2 OFLT012 filters must be used.



The air filter is complete with containment frame and protection nets in electrowelded galvanized steel wire.

2.4 REGULATION DAMPERS

Figure 2.5 Regulation damper

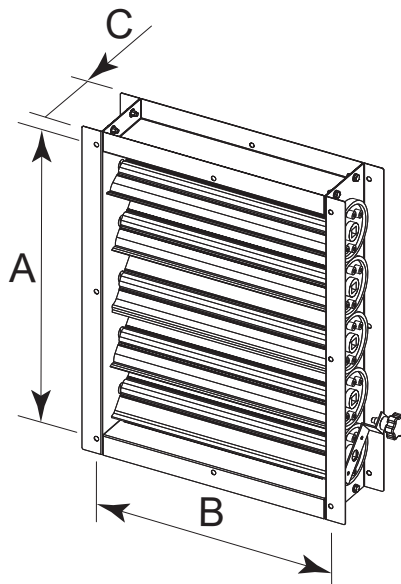

Table 2.4 Regulation dampers

Code	Figure	Use	A (1)	B (1)	C
OSRR000	2.5 p. 10	M20 C	527	420	120
OSRR001		M30 C	527	520	120
OSRR002		M60 C	527	1020	120

- Measures referred to the holes centre distance.

2.5 ANTI-VIBRATION CONNECTIONS

Figure 2.6 Anti-vibration connection

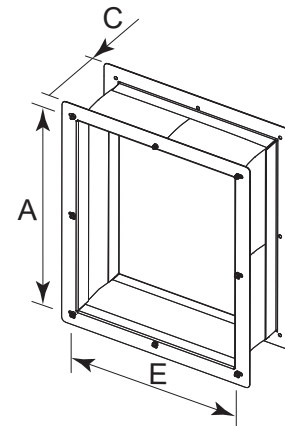

Table 2.5 Anti-vibration connections

Code	Figure	Use	A (1)	B (1)	C
OGTV013	2.6 p. 10	M20 C	520	420	> 95 < 170
OGTV000		M30 C	520	520	> 95 < 170
OGTV009		M60 C	520	1020	> 95 < 170

- Measures referred to the holes centre distance.

2.6 BASE FRAME



It is recommended to use this optional only when using the mixing chamber kit (Paragraph 2.1 p. 9).

Figure 2.7 Base frame

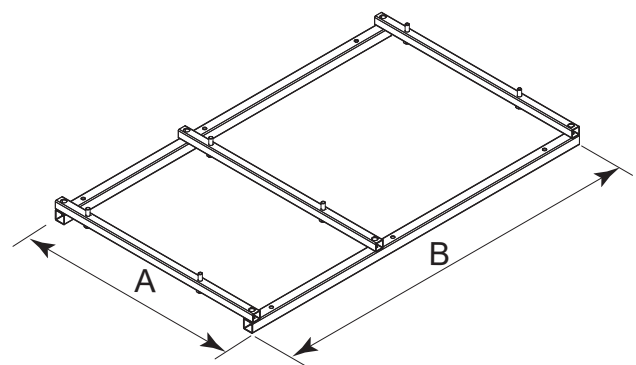

Table 2.6 Base frame

Code	Figure	Use	A	B
OSPP004	2.7 p. 10	M20 C	650	1077
OSPP005		M30 C	790	1077
OSPP006		M60 C	1290	1077