

1 PIPES

1.1 MATERIALS

The proposed pipes are made of AISI 316 L 2B steel and meet the requirements of EN 1856-1 standard.

1.2 FEATURES

Table 1.1 Flue gas exhaust and combustion air inlet pipes

Code	Figure	D	L	Clamp (1)	Gasket (2)	Flue gas analysis socket
OTBO008	1.1 p. 1	80	500	yes	yes	no
OTBO009		80	1000	yes	yes	no
OTBO003		110	500	no	yes	no
OTBO001		110	1000	no	yes	no
OTBO004		130	500	no	yes	no
OTBO002		130	1000	no	yes	no
OTBO020	1.2 p. 1	80	1000	yes	no	yes
OTBO005		110	1000	no	no	yes
OTBO006		130	1000	no	no	yes

- 1 Figure 7.1 p. 8.
- 2 Double lip silicone seal, maximum temperature 230 °C, operating temperature 200 °C.

Figure 1.1 Pipe

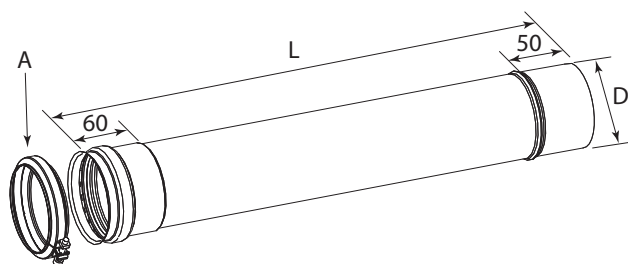

A Pipe clamp (standard for pipes Ø 80 mm)

Figure 1.2 Pipe with flue gas analysis socket

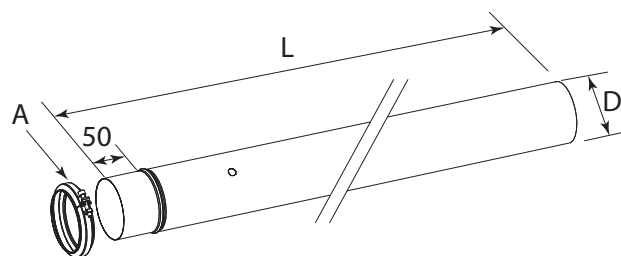

A Pipe clamp (standard for pipes Ø 80 mm)

1.3 ADAPTERS

Table 1.2 Adapters

Code	Figure	D	d	Gasket (1)
ODTT003	1.3 p. 1	110	80	yes
ODTT004		130	80	yes

- 1 Double lip silicone seal, maximum temperature 230 °C, operating temperature 200 °C.

Figure 1.3 Adapter for exhaust/air pipes

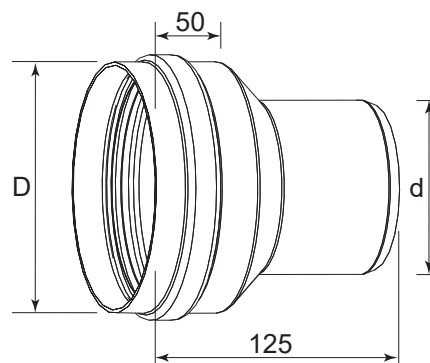

2 ELBOWS

Table 2.1 Flue gas exhaust and combustion air inlet elbows

Code	Figure	D	Type	Clamp (1)	Gasket (2)
OCRV006	2.1 p. 2	80	45°	yes	yes
OCRV003	2.2 p. 2	110	45°	yes	yes
OCRV004	2.3 p. 2	130	45°	yes	yes
OCRV007	2.4 p. 2	80	90°	yes	yes
OCRV001	2.5 p. 2	110	90°	yes	yes
OCRV002	2.6 p. 2	130	90°	yes	yes
OCRV013	2.7 p. 2	80	45°	no	

1 Figure 7.1 p. 8.
 2 Double lip silicone seal, maximum temperature 230 °C, operating temperature 200 °C.

Figure 2.1 OCRV006

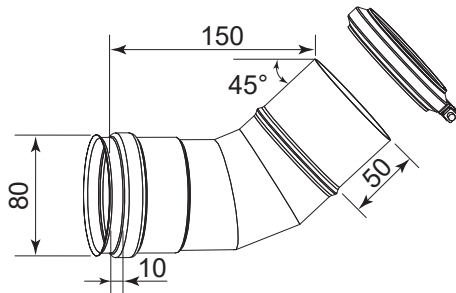

Figure 2.2 OCRV003

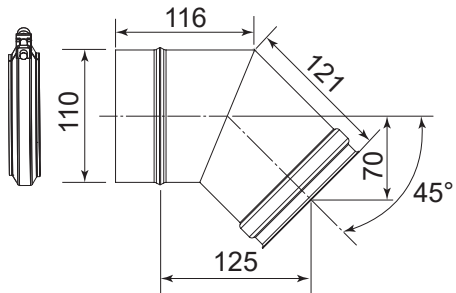

Figure 2.3 OCRV004

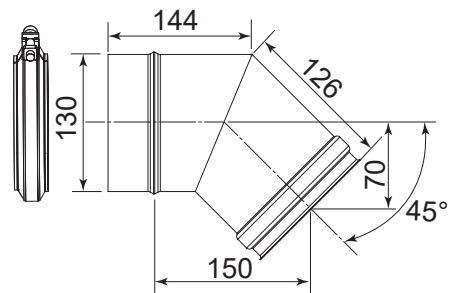

Figure 2.4 OCRV007

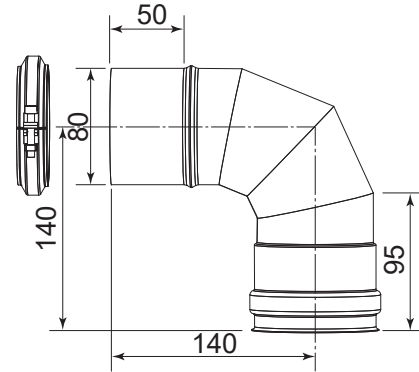

Figure 2.5 OCRV001

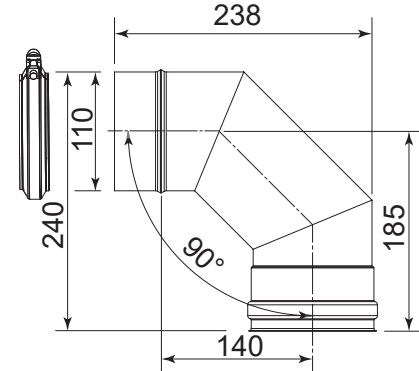

Figure 2.6 OCRV002

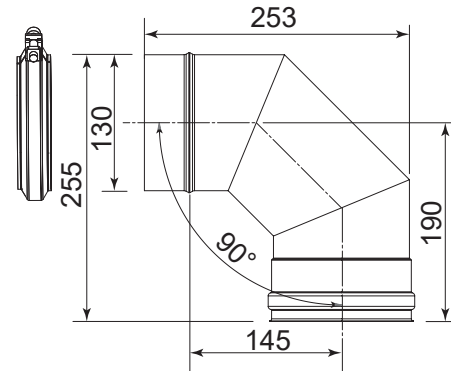
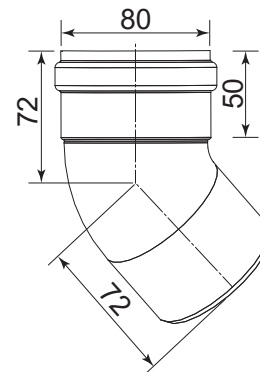

Figure 2.7 OCRV013



3 SPLIT PIPE KIT

Figure 3.1 OSCR006 split pipe flue gas exhaust

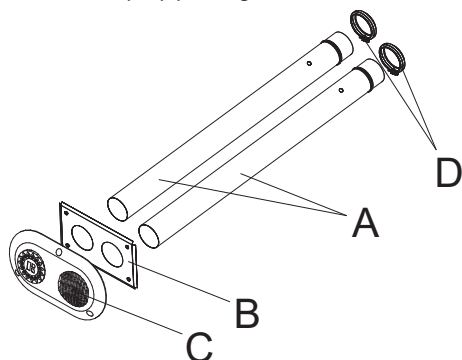

Figure 3.2 OSCR004 split pipe flue gas exhaust

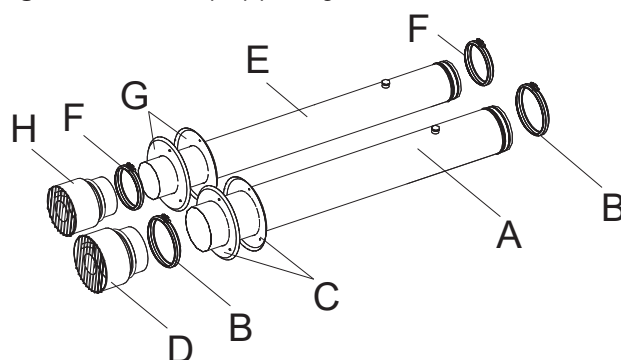

Table 3.1 OSCR006 flue gas exhaust composition

	Code	D	L	Quantity	Figure
A	RTBO116	80	1000	2	1.2 p. 1
B	RRSN000	-	-	1	-
C	RTRM029	-	-	1	6.3 p. 8
D	NFSC010	80	-	2	7.1 p. 8

Table 3.2 OSCR004 flue gas exhaust composition

	Code	D	L	Quantity	Figure
A	RTBO790	130	1000	1	-
B	NFSC001	130	-	2	7.1 p. 8
C	RRSN003	130	-	2	-
D	KTRM008	130	-	1	-
E	RTBO790	110	1000	1	-
F	NFSC000	110	-	2	7.1 p. 8
G	RRSN002	110	-	2	-
H	KTRM009	110	-	1	-

4 COAXIAL FLUE GAS EXHAUSTS

For the identification of coaxial ducts, the first number refers to the connection diameter of the individual ducts, while the second refers to the diameter of the coaxial duct.

For example Ø 80/125 refers to a coaxial duct with connection diameters of the individual air/exhaust ducts 80 mm and coaxial duct diameter 125 mm.

Table 4.1 Coaxial flue gas exhausts

	Wall coaxial				Roof coaxial			
	OSCR012 Ø 80/125 mm	OSCR011 Ø 130/180 mm	OSCR007 Ø 80/125 mm	OKTC004 Ø 130/180 mm	OSCR008 Ø 80/125 mm	OSCR009 Ø 100/150 mm	OKTC001 Ø 130/210 mm	OSCR002 Ø 130/210 mm
R15	-	-	*	*	*	*	*	-
R20	-	-	*	*	*	*	*	-
R30	-	-	*	*	*	*	*	-
R40	-	-	*	*	*	*	*	-
R50	-	-	*	*	*	*	*	-
R60	-	-	-	*	-	*	*	-
R80	-	-	-	*	-	*	*	-
G30	*	*	-	-	*	*	*	-
G45	*	*	-	-	*	*	*	-
G60	*	*	-	-	*	*	*	-
G100	*	*	-	-	*	*	*	-
K32	*	*	-	-	*	*	*	-
K45	*	*	-	-	*	*	*	-
K60	-	*	-	-	-	*	*	-
K100	-	*	-	-	-	-	*	-
M20	-	-	-	-	-	-	-	*
M25	-	-	-	-	-	-	-	*
M30	-	-	-	-	-	-	-	*
M35	-	-	-	-	-	-	-	*
M40	-	-	-	-	-	-	-	*
M50	-	-	-	-	-	-	-	*
M60	-	-	-	-	-	-	-	*

* Applicable
- Not applicable

4.1 WALL

4.1.1 OSCR012

Figure 4.1 OSCR012 wall coaxial flue gas exhaust

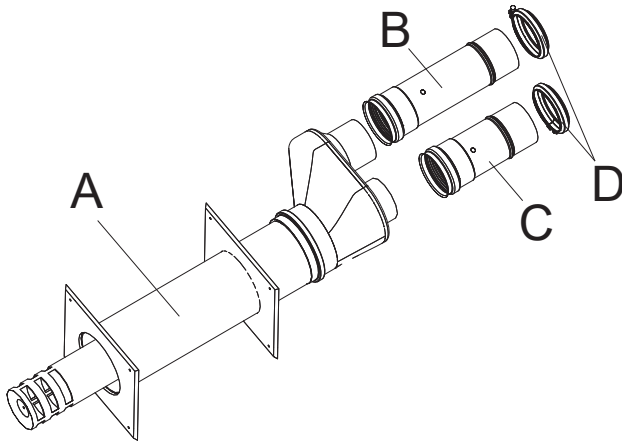

Table 4.2 OSCR012 flue gas exhaust composition

	Code	D	L	Quantity	Figure
A	RTBO122	125	780	1	4.2 p. 4
B	RTBO559 (1)	80	275	1	4.3 p. 4
C	RTBO124 (1)	80	195	1	4.4 p. 4
D	NFSC010	80	-	2	7.1 p. 8

1 Complete with double lip silicone seal, maximum temperature 230 °C, operating temperature 200 °C.

Figure 4.2 RTBO122

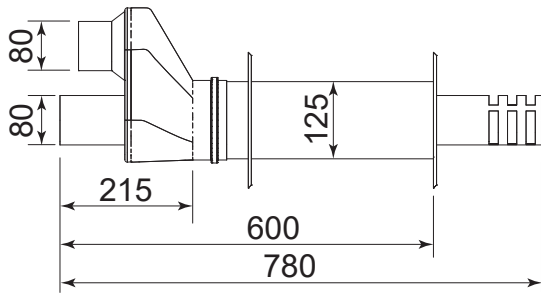

Figure 4.3 RTBO559

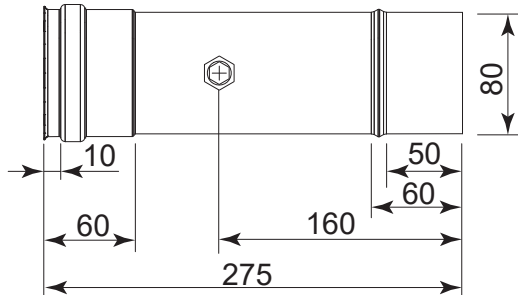
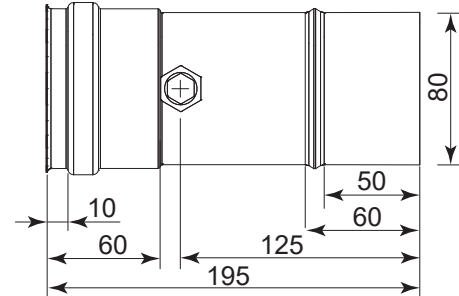

Figure 4.4 RTBO124



4.1.2 OSCR011

Figure 4.5 OSCR011

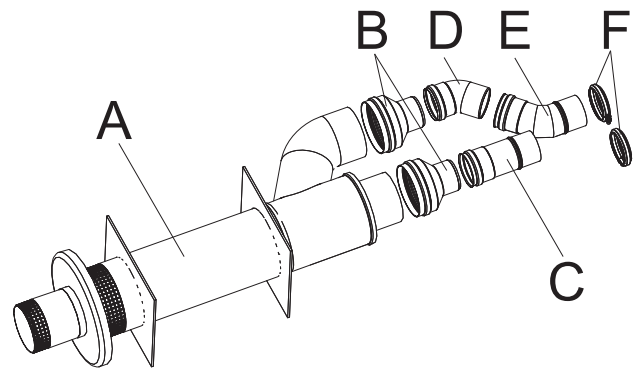

Table 4.3 OSCR011 flue gas exhaust composition

	Code	D	L	Quantity	Figure
A	KOPT034	180	1000	1	4.6 p. 4
B	RDTT008	130/80	-	2	1.3 p. 1
C	RTBO160 (1)	80	185	1	4.7 p. 5
D	RCRV027	80	-	1	2.7 p. 2
E	RCRV015	80	-	1	2.1 p. 2
F	NFSC010	80	-	2	7.1 p. 8

1 Complete with double lip silicone seal, maximum temperature 230 °C, operating temperature 200 °C.

Figure 4.6 KOPT034

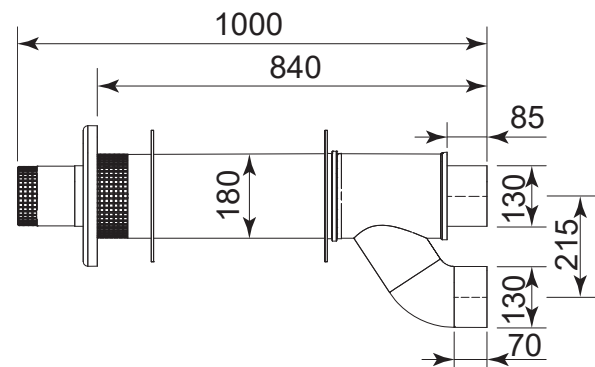
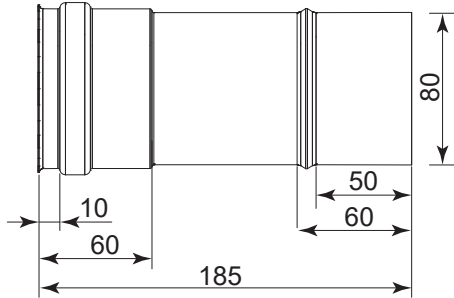

Figure 4.7 RTBO160



	Code	D	L	Quantity	Figure
D	RCRV027	80	-	1	2.7 p. 2
E	RCRV015	80	-	1	2.1 p. 2
F	NFSC010	80	-	2	7.1 p. 8

1 Complete with double lip silicone seal, maximum temperature 230 °C, operating temperature 200 °C.

4.1.3 OSCR007

Figure 4.8 OSCR007

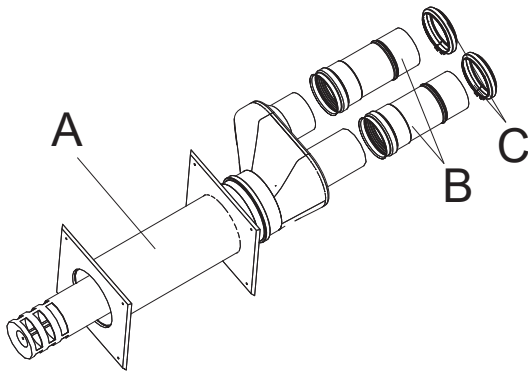

Table 4.4 OSCR007 flue gas exhaust composition

	Code	D	L	Quantity	Figure
A	RTBO122	125	780	1	4.2 p. 4
B	RTBO124 (1)	80	195	2	4.4 p. 4
D	NFSC010	80	-	2	7.1 p. 8

1 Complete with double lip silicone seal, maximum temperature 230 °C, operating temperature 200 °C.

4.1.4 OKTC004

Figure 4.9 OKTC004

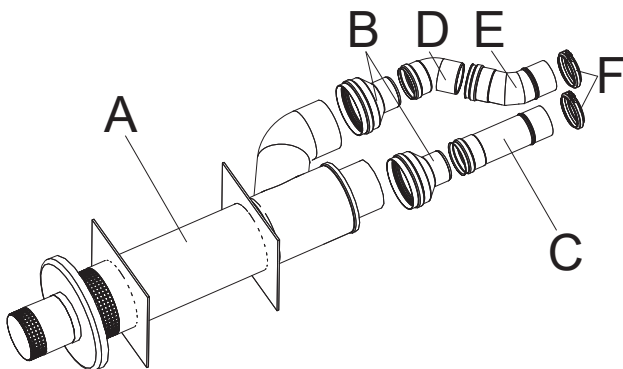
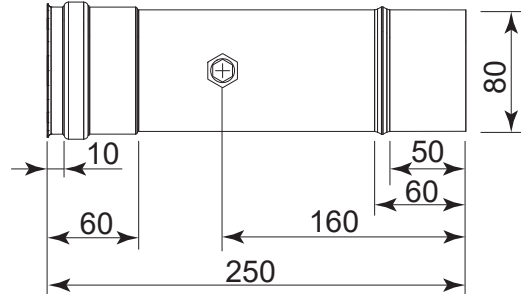

Table 4.5 OKTC004 flue gas exhaust composition

	Code	D	L	Quantity	Figure
A	KOPT034	180	1000	1	4.6 p. 4
B	RDTT008	130/80	-	2	1.3 p. 1
C	RTBO117 (1)	80	250	1	4.10 p. 5

Figure 4.10 RTBO117



4.2 ROOF

4.2.1 OSCR008

Figure 4.11 OSCR008

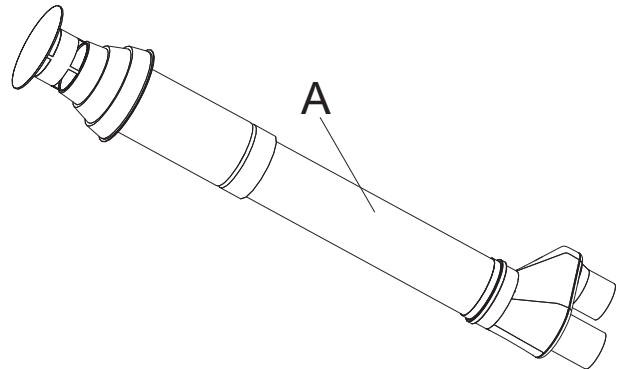
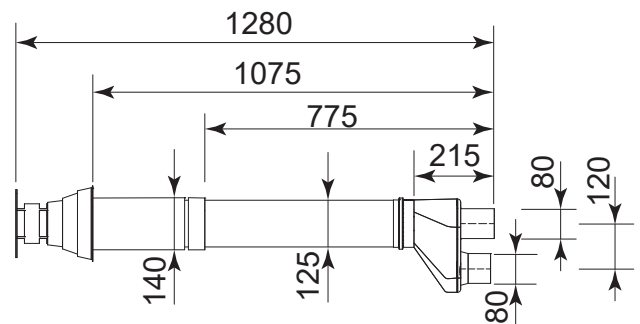

Table 4.6 OSCR008 flue gas exhaust composition

	Code	D	L	Quantity	Figure
A	RTBO123	125	1280	1	4.12 p. 5

Figure 4.12 RTBO123



4.2.2 OSCR009

Figure 4.13 OSCR009

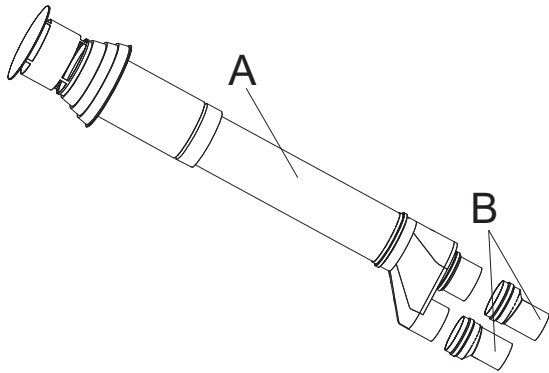

Table 4.7 OSCR009 flue gas exhaust composition

	Code	D	L	Quantity	Figure
A	RTBO129	150	1360	1	4.14 p. 6
B	RDTT004 (1)	100/80	150	2	4.15 p. 6

1 Complete with double lip silicone seal, maximum temperature 230 °C, operating temperature 200 °C.

Figure 4.14 RTBO129

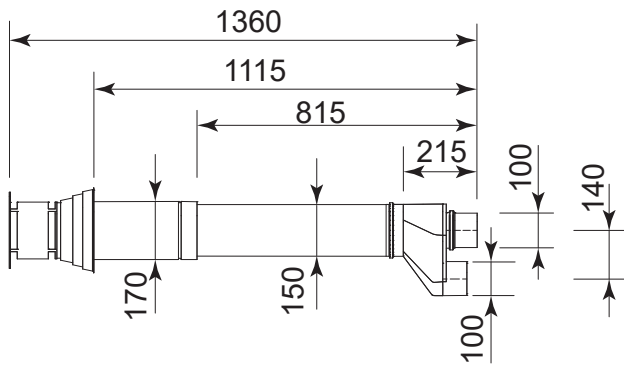
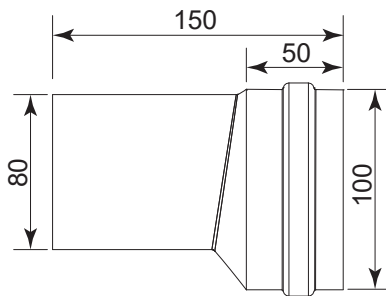

Figure 4.15 RDTT004



4.2.3 OKTC001

Figure 4.16 OKTC001

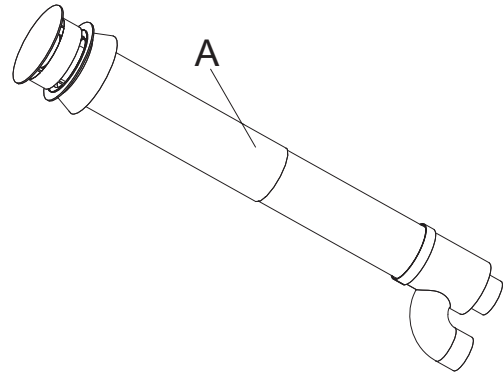
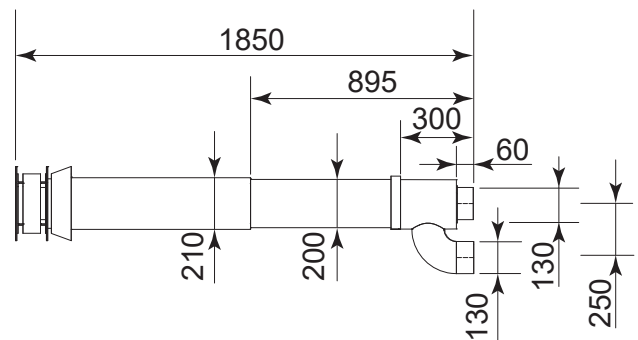

Table 4.8 OKTC001 flue gas exhaust composition

	Code	D	L	Quantity	Figure
A	KOPT033	210	1850	1	4.17 p. 6

Figure 4.17 KOPT033



4.2.4 OSCR002

Figure 4.18 OSCR002

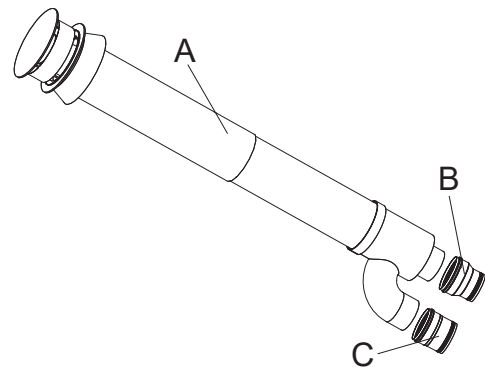

Table 4.9 OSCR002 flue gas exhaust composition

	Code	D	L	Quantity	Figure
A	KOPT033	210	1850	1	4.17 p. 6
B	RDTT003 (1)	110/130	125	1	4.20 p. 7
C	RDTT002 (1)	130/134	125	1	4.19 p. 7

1 Complete with double lip silicone seal, maximum temperature 230 °C, operating temperature 200 °C.

Figure 4.19 RDTT002

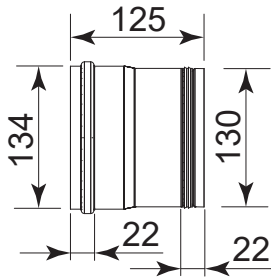
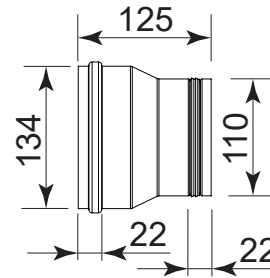
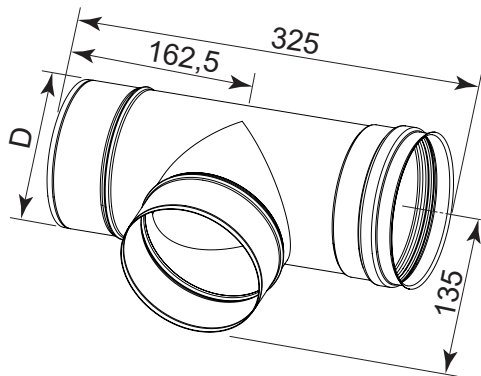

Figure 4.20 RDTT003



5 T CONNECTORS

Figure 5.1 T connector



5.1 CAPS FOR T CONNECTORS

Figure 5.2 Cap for T connector

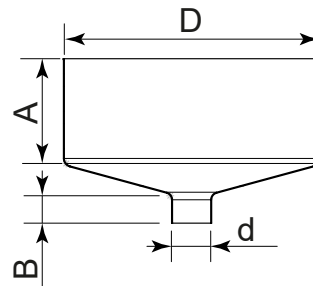

Table 5.1 T connectors

Code	Figure	D	Clamp (1)	Gasket (2)
ORCC002	5.1 p. 7	80	yes	yes
ORCC000		110	yes	yes
ORCC001		130	yes	yes

- Figure 7.1 p. 8.
- Double lip silicone seal, maximum temperature 230 °C, operating temperature 200 °C.

Table 5.2 Caps for T connectors

Code	Figure	D	d	A	B	Clamp (1)
OTPP002 (2)	5.2 p. 7	80	3/4"	52	16	yes
OTPP000		110	3/4"	57	24	yes
OTPP001		130	20	54	14	yes

- Figure 7.1 p. 8.
- Complete with double lip silicone seal, maximum temperature 230 °C, operating temperature 200 °C.

6 TERMINALS

6.1 ROOF

Table 6.1 Roof terminals

Code	Figure	A	B	C	D	E	F
OTRM004 (1)	6.1 p. 7	200	185	130	80	95	55
OTRM000		300	210	165	110	80	45
OTRM001		300	185	140	130	80	45

- Complete with clamp, refer to Figure 7.1 p. 8.

Figure 6.1 Roof terminal

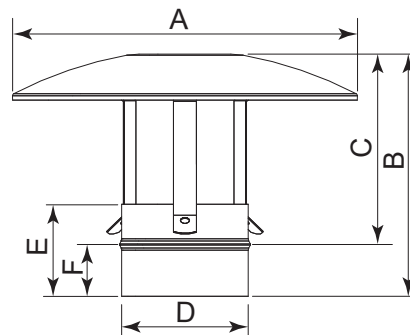

6.2 WALL

Table 6.2 Wall terminal

Code	Figure	D	d	A	B
O12141320	6.2 p. 8	109	79	69	80
O12141330		141	109	69	80
O12141340		162	129	69	80

Figure 6.2 Wall terminal

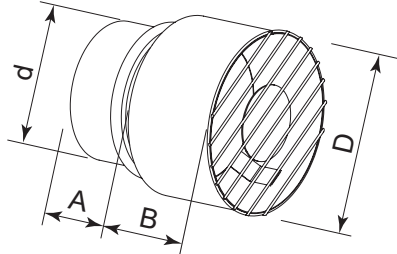
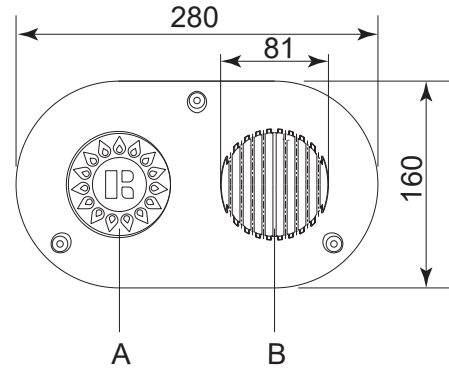

Figure 6.3 OTRM005 double die-cast wall mounted terminal



A Combustion air inlet
B Flue gas exhaust

The terminal protrudes from the wall 22 mm.



The die-cast terminal is not applicable to the M series.

7 PIPE CLAMPS

Figure 7.1 Pipe clamp

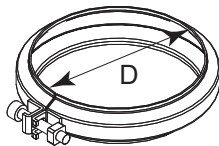

Table 7.1 Pipe clamps

Code	Figure	D
OFSC000	7.1 p. 8	110
OFSC001		130
OFSC010		80

8 PIPE ADAPTERS

The adapters allow the connection between M and M C series gas unit heaters and commercially available pipes.

Table 8.1 Pipe adapters

Code	Figure	D	d
OTBO011 (1)	8.1 p. 8	111	110
OTBO012 (1)		131	130

1. Complete with external o-ring (gas unit heater side) and internal double lip silicone seal, maximum temperature 230 °C, operating temperature 200 °C.

Figure 8.1 Pipe adapter

