

APPROVAL REQUIRED	PLEASE VERIFY	DRAWING NOTES
<input type="checkbox"/> APPROVED AS DRAWN	1. PLEASE SELECT ALUMINUM ANODIZE COLOR: <input type="checkbox"/> CLEAR <input type="checkbox"/> DARK BRONZE	1. THIS WILL BE FABRICATED & SHIPPED TO THE EXACT DIMENSION SHOWN.
<input type="checkbox"/> APPROVED AS NOTED	2. PLEASE SELECT GLAZING RATING: <input type="checkbox"/> U.L. LEVEL 1 <input type="checkbox"/> U.L. LEVEL 2 <input type="checkbox"/> U.L. LEVEL 3 CONTACT T.S.S. FOR LEVEL 4-5 & 7-8 OPTIONS (LEVEL 3 MEETS LEVEL 6 REQUIREMENTS)	2. ALL DIMENSIONS MUST BE APPROVED, SIGNED, DATED, OR OTHERWISE NOTED ON THIS DRAWING BEFORE FABRICATION CAN BEGIN.
SIGNATURE:	3. PLEASE SELECT GLAZING MATERIAL TYPE: <input type="checkbox"/> UNCOATED ACRYLIC (LVL 1 & 2 ONLY) <input type="checkbox"/> ABRASION RESISTANT ACRYLIC (LVL 1 & 2 ONLY) <input type="checkbox"/> LAMINATED POLYCARB./ACRYLIC (LVL 1, 2, & 3) <input type="checkbox"/> GLASS CLAD POLYCARBONATE (LVL 1, 2, & 3)	3. FINISHED OPENING SIZE: 36 1/4" x 36 1/4".
DATE:	4. PLEASE SELECT COUNTER TOP MATERIAL: <input type="checkbox"/> BLACK PLASTIC LAMINATE <input type="checkbox"/> 18 GA. S/S - #4 FIN.	4. VOICE PORT WILL BE CENTERED IN UNIT, UNLESS OTHERWISE SPECIFIED (TYP. 60" A.F.F.).
		5. ALUMINUM COLOR MUST BE SPECIFIED FOR THE ENGINEERING TO BEGIN.
		* IN THE EVENT OF CONFLICTS OR DISCREPANCIES AMONG THE CONTRACT DOCUMENTS, INTERPRETATIONS WILL GIVE PRIORITY TO THE TOTAL SECURITY SOLUTIONS APPROVAL DRAWINGS OVER THE PROPOSAL OR ANY OTHER DOCUMENT PROVIDED OR INCLUDED IN THE AGREEMENT.

() UNIT(S) REQUIRED

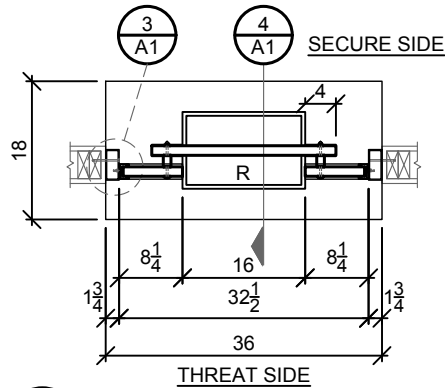

1 PLAN
A1

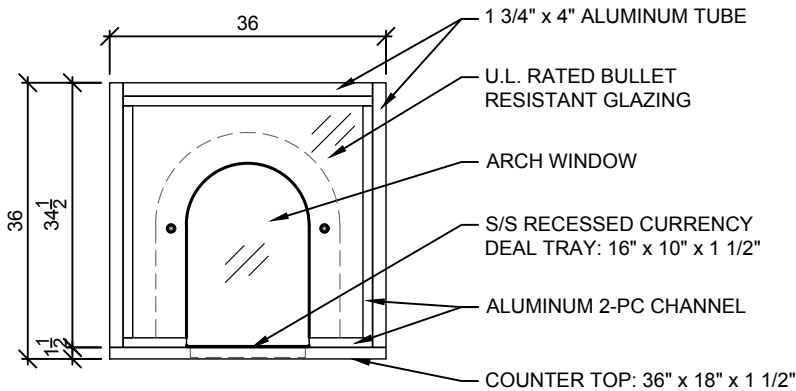

2 ELEVATION
A1

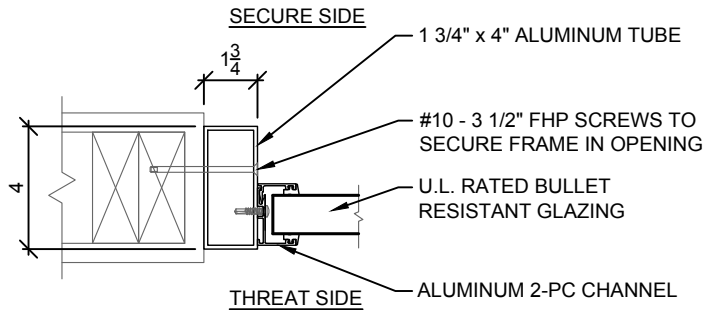

3 DETAIL
A1

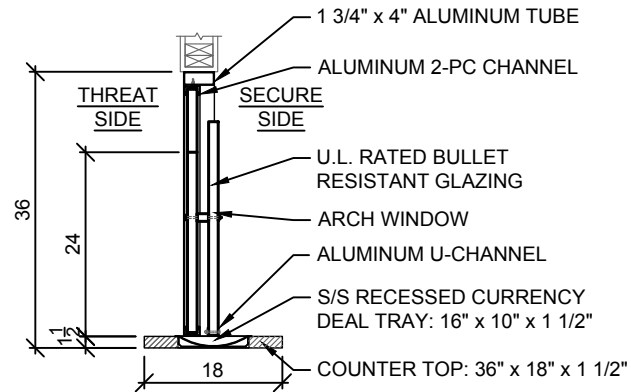

4 SECTION
A1

SHEET NUMBER:	A1
DATE:	01.01.12
DRAWN BY:	XXX
ENG. BY:	YYY
CHECKED BY:	XX

PROJECT NAME:
ARCHED INTERIOR TRANSACTION WINDOW WITH COUNTER TOP & S/S RECESSED DEAL TRAY

The information in this drawing is confidential and is the property of TOTAL SECURITY SOLUTIONS. When reproduced or used for any other purpose without the written permission of TOTAL SECURITY SOLUTIONS, the user assumes all liability.

Total Security Solutions
935 Garden Lane
Fowlerville, MI 48836
Phone: 866.947.8075 Fax: 517.223.0805
www.tssbulletproof.com

TOTAL SECURITY SOLUTIONS