

PUMPS



TY-300HX INDUSTRIAL PUMP

SPECIFICATIONS

Maximum Pressure	20,000 PSI
Max Flow	28.7 GPM
Horsepower	150 HP

APPLICATIONS

- Water Blasting
- Chemical Injection
- Hydrostatic Testing
- Boiler Feed
- Evaporator Cleaning

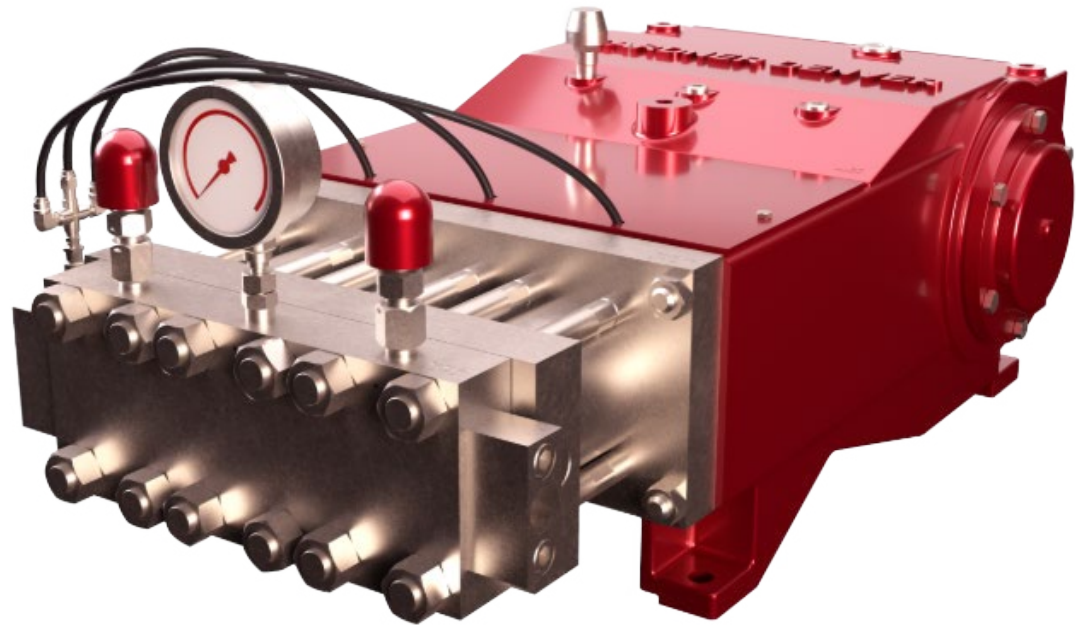

	PLUNGER DIAMATER		MAX PRESSURE		FLOW					
					200 RPM		400 RPM		600 RPM	
	in.	mm.	PSI	bar	GPM	LPM	GPM	LPM	GPM	LPM
TY-300HX	0.787	20	20000	1379	3.8	14.4	7.6	28.8	11.4	43.2
	0.875	22	16500	1138	4.7	17.8	9.41	35.6	14.1	53.4
	1.000	25	12500	862	6.1	23.1	12.2	46.2	18.4	69.7
	1.125	29	10000	689	7.8	29.5	15.5	58.7	23.2	87.8
	1.250	32	8000	552	9.6	36.3	19.1	72.3	28.7	108.6

All flows are based on 100% volumetric efficiency. All flows realized will vary dependent upon several factors, such as but not limited to: pump speed, pump pressure, plunger size and pumped fluid. "Typical" actual flow rates will be approximately 95% of values shown above.

TY-300HX INDUSTRIAL PUMP

SPECIFICATIONS

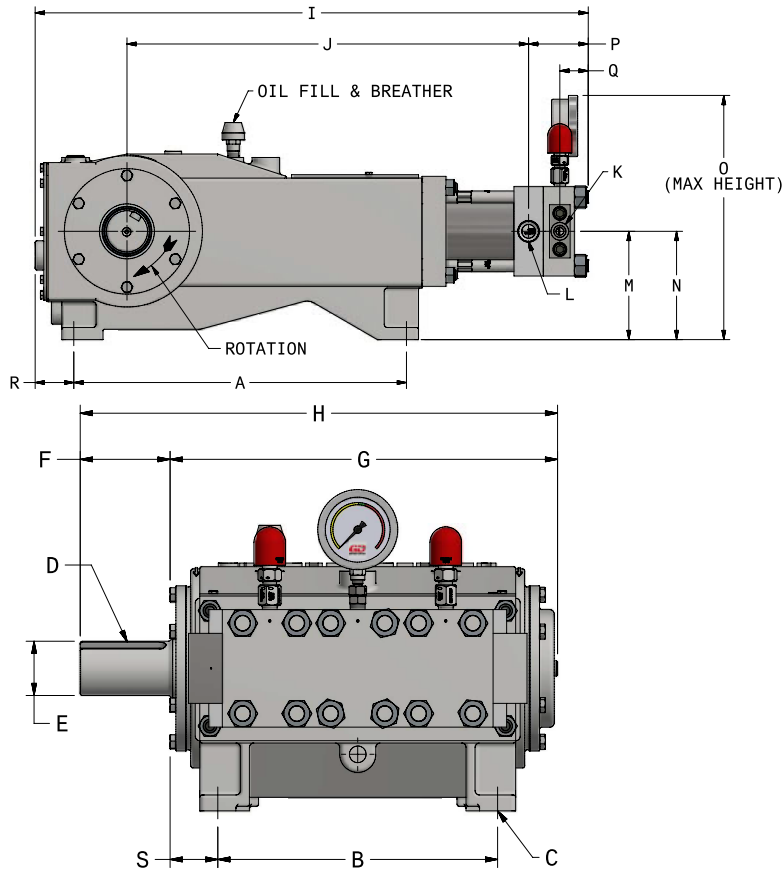

STANDARD FEATURES

- Featuring GD Energy Products' industry leading Redline Consumables for extended maintenance intervals
- Full cast ductile iron frame fluid end offers superior strength
- Large valve cover access panels for easy valve change outs
- All parts 100% made in the USA, guaranteeing build quality and reliability in the field
- Upgraded internal components and seal housing prevent contamination
- Coated crankshaft bearings to extend power end life
- Next generation fluid end technology with innovative geometry to minimize stress
- Left or right side suction and discharge connections
- Left or right handed keyed shaft extension
- Pressure lubricated power end (via engine driven oil pump—not supplied)
- Clamp style connections between piston rod and crosshead extensions
- Rod wash spray bar and baffles
- Multiple Drive Options:
 - Hydraulic Drive
 - Teardrop Spur Gearbox
 - Planetary Gearbox
- In-line fluid end design
- Pressure range of 8,000 PSI to 20,000 PSI
- Flow rates from 3.8 GPM to 28.7 GPM
- High volumetric efficiency for maximum horsepower utilization
- Maximum frame load of 10,000 Lbs / 4535 Kg
- Field proven design
- Extremely reliable
- Easy field maintenance
- Available in all stainless steel fluid end construction
- Manufactured on state-of-the-art machinery
- Rigorously subjected to full load testing
- Quick Change Plungers for easy maintenance
- Soft Seated Inline Valves for Durability

	A	B	C	D	E	F	G	H	I	J	K	L	M	N	O	P	Q	R	S
in.	24.30	15.50	0.81	0.75	3.00	4.98	21.46	26.44	40.31	29.28	3/4" NPT (15K PSI) 1" MP (20K PSI)	1-1/4" NPT	7.88	7.88	18.00	4.35	2.08	2.81	2.65
mm.	617.2	393.7	20.6	19.1	76.2	126.5	545.1	671.6	1023.9	743.7	743.7		200.2	200.2	457.2	110.5	52.8	71.4	67.3