

MODULES

**GD**  
ENERGY PRODUCTS

## **5000 HD PSI** **DRILLING MODULE**

### **HIGHEST PERFORMING DRILLING MODULE TECHNOLOGY**

GD Energy Products drilling modules are compact and built to last, delivering high performance, pressure and flow rates up to 3 times longer than others. Made with individually forged, heat-treated alloy steel using our proprietary Autofrettage technique, each module offers extended life and maximum strength, yet can be welded to repair washouts. And service is simple with built-in Falcon Technology, with a single-piece, twist-in retainer, and no fasteners required.

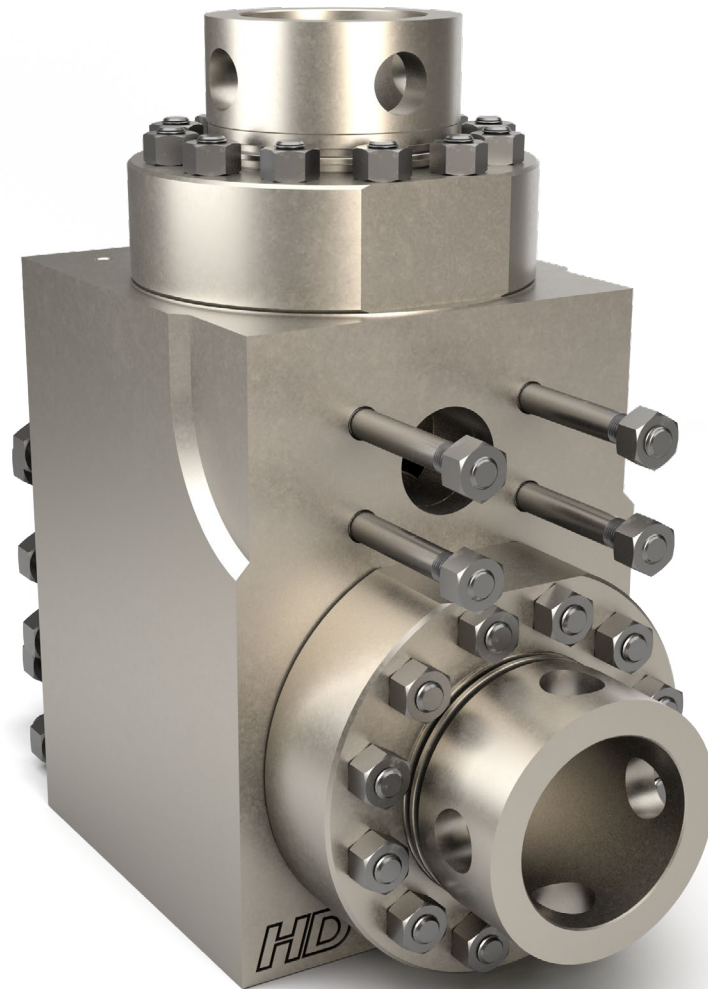

# 5000 HD PSI DRILLING MODULE

## SPECIFICATIONS

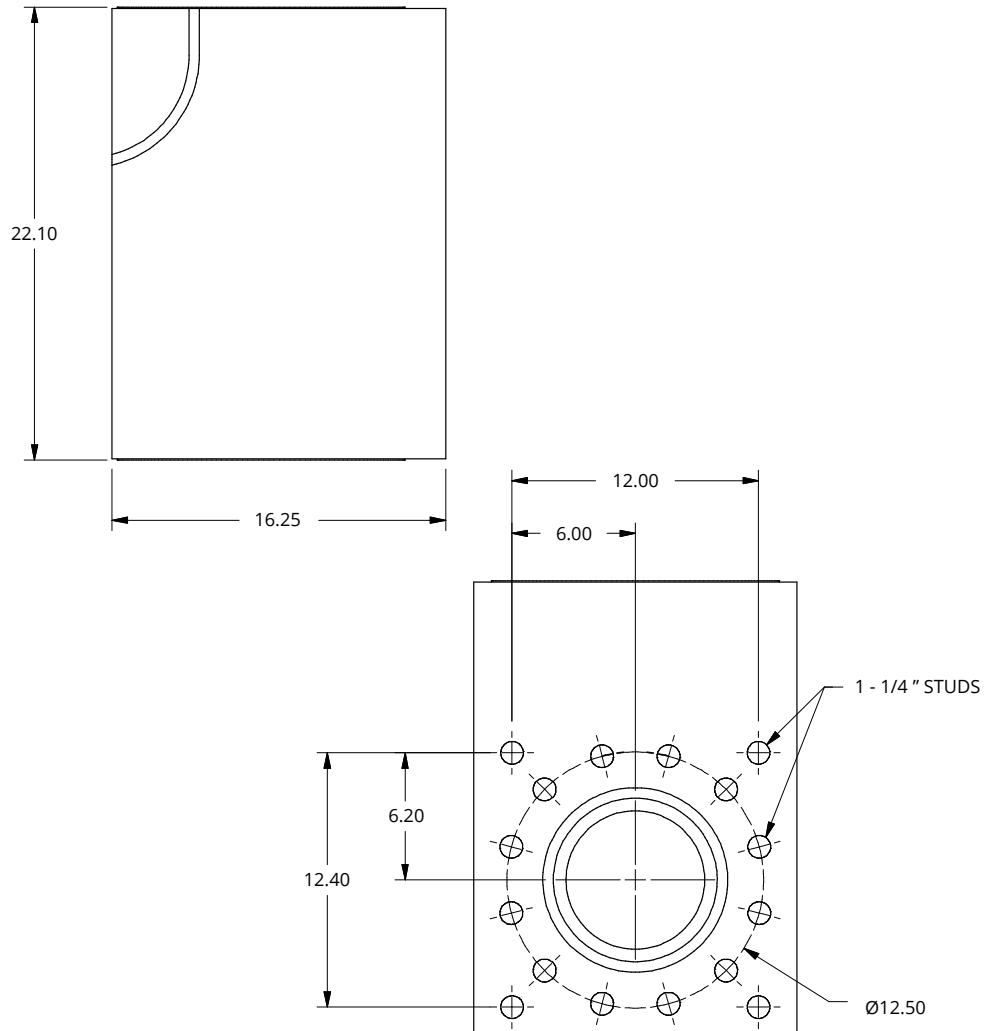

## STANDARD FEATURES

- Individually forged, heat-treated alloy steel
- Autofrettaged module - maximizes strength, yet module can be welded to repair washouts
- Direct replacement for the current 5000 psi wide body module
  - Same outside dimensions
  - Same external and internal components except valve cover, bore seal and Falcon spring retainer
- Valve cover bore seal for improved seal performance
- Falcon technology for improved serviceability
  - Single-piece twist-in retainer
  - No fasteners required
- Improved internal geometry to minimize operating stresses
- Module designed to accommodate either Falcon or standard valve spring retainer
- DNV certifiable
- Capable of 5 inches to 8 inches in piston sizes