

# PUMPS



## GD 1000Q HD WELL SERVICE PUMP

The GD 1000Q HD is designed and built to be the best 1000HP pump on the market. Robust design and the industry's best fluid end technology, make the GD 1000Q HD the preferred pump for pump-downs, coil tubing, well drill-out, and other tough applications.

### SPECIFICATIONS

Maximum Input	1,000 BHP (746 kW)
Maximum RPM	450 RPM
No. of Plungers	5
Stroke Length	6 in (152 mm)
Plunger Load	106,000 lb (471,512 N)
Pump Weight	7,000 lb (3,175 kg)
Gear Ratio	4.6:1



PLUNGER DIAMETER		DISPLACEMENT PER REVOLUTION		DISPLACEMENT AT PUMP RPM - INTERMITTENT SERVICE															
				50				100				300				450			
in.	mm.	Gallons	m <sup>3</sup>	GPM	LPM	PSI	bar	GPM	LPM	PSI	bar	GPM	LPM	PSI	bar	GPM	LPM	PSI	bar
2.75	70	0.77	0.0029	39*	146*	17998*	1241*	116	438	13332	919	231	876	6666	460	347	1314	4444	306
3	76	0.92	0.0035	46	174	15124	1043	138	521	11203	772	275	1042	5601	386	413	1564	3734	257
3.5	89	1.25	0.0047	62	236	11111	766	187	709	8231	567	375	1419	4115	284	562	2128	2744	189
4	102	1.63	0.0062	82	309	8507	587	245	927	6301	434	490	1853	3151	217	734	2780	2100	145
4.5	114	2.07	0.0078	103	391	6722	463	310	1173	4979	343	620	2345	2489	172	929	3518	1660	114

\*Contact GD Energy Products engineering for application review and approval

# GD 1000Q HD

## WELL SERVICE PUMP

### SPECIFICATIONS

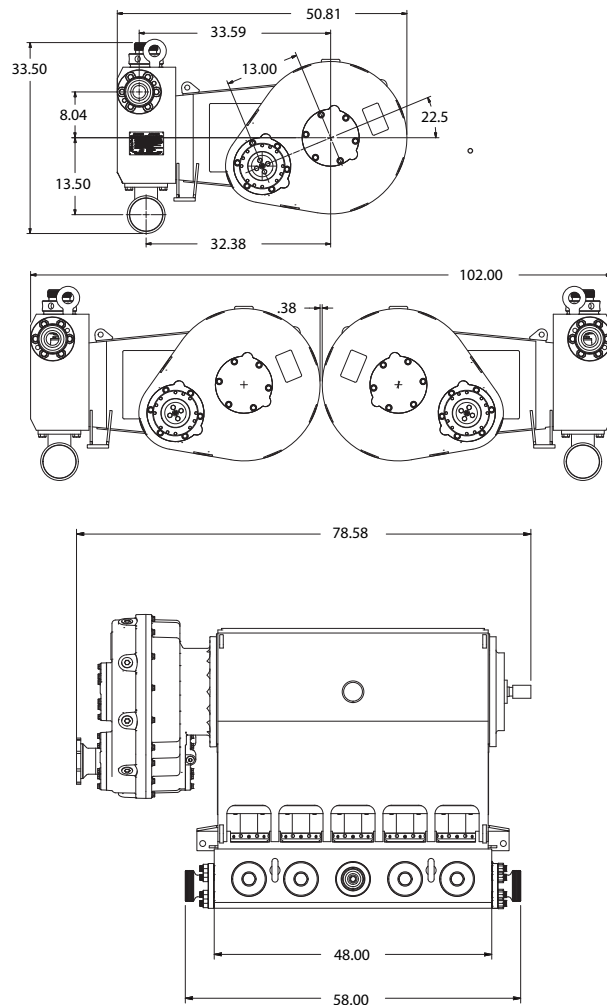

NOTE: Installation drawing shown with Next Generation fluid end geometry. Additional drawings are available from engineering per application.

### STANDARD FEATURES

- Next Generation fluid-end geometry allows back-to-back fitment and extends life; includes the patented Falcon Retainer System and interchangeable covers
- Upgraded internal components and seal housing prevent contamination
- Featuring GD Energy Products' industry leading Redline packing, valves, seats, and plungers for extended maintenance intervals
- Available in specially formulated Stainless Steel, or standard high grade Carbon Steel
- Next Generation fluid end available with different mounting hole locations to fit competitor power ends
- Thunder coated bearings extend power end life
- Fabricated power frame weldment with integrated crankcase and crosshead slides
- Parallel shaft gearbox with left or right side mounting positions
- Multiple gearbox input pinion positions
- Forged, heat treated alloy steel crankshaft
- Cross drilled crankshaft and connecting rod for pressurized oil flow to critical components
- Replaceable crosshead slides
- Forged SAE 4330 autofrettaged fluid end for extended field service
- Through stud fluid end design for maintenance and removal ease
- Replaceable stuffing boxes allowing convenient plunger size conversion
- Suction manifold with victaulic connections

### OPTIONAL FEATURES

- DNV, ABS, PED or other third party certifications
- Splined flange for gear reducer
- Various plunger packing styles
- Additional center gauge connection
- Hydraulic torque wrench for fluid end removal
- Multiple suction manifold configurations including valve lifter options to drain chambers