

MODULES

F-SERIES DRILLING MODULES

Made for extended life and maximum strength, our F-Series drilling module is well known for its innovative design and rugged reliability, giving customers peace of mind when drilling in today's tough environments.

STANDARD FEATURES

- L-Shaped design for F-1300/1600 series pumps
- Two-piece, "will fit" design features compatible mounting footprint with competing designs
- Wear plate and valve covers feature bore seal technology for improved sealing
- Individually forged, heat-treated alloy steel
- Autofrettaged module – maximizes strength, yet module can be welded to repair washouts
- Valve cover bore seal for improved seal performance at the valve covers and wear ring plate (7,500 psi cylinders only)
- Unique Bore Seal Technology providing increased life span and reduced maintenance costs
- Patent-pending Falcon Technology for improve serviceability (for valve-overvalve cylinders)
 - Single-piece twist-in retainer
 - No fasteners required
- Improved internal geometry to minimize operating stresses
- Utilizes API 7 valves for increased flow and lower velocity

GD
ENERGY PRODUCTS



F-SERIES

DRILLING MODULES

SPECIFICATIONS VALVE OVER VALVE

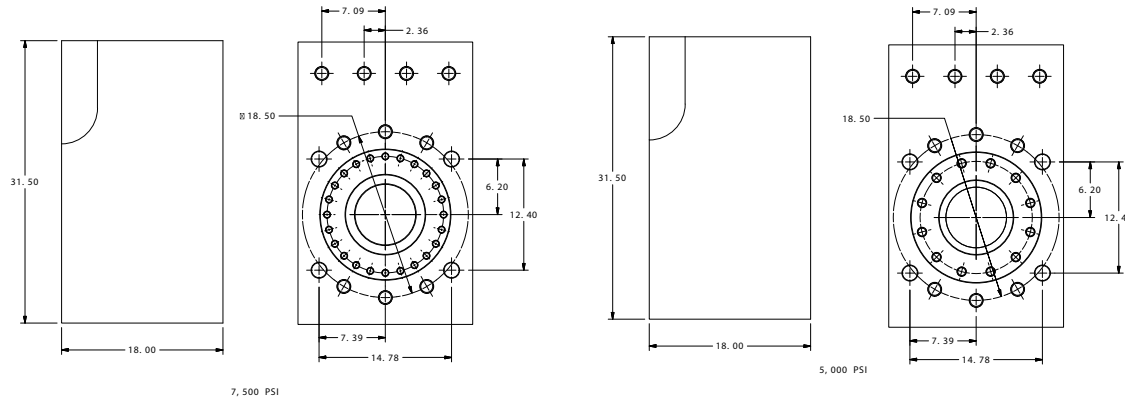

SPECIFICATIONS L-SHAPE

