

PUMPS



GD 250HDD HORIZONTAL DIRECTIONAL DRILLING PUMP

Built on GD Energy Products' legacy of product innovation in pumping technology, the GD 250HDD pump is designed to serve a wide variety of HDD applications. A high rod load makes the pump rugged and durable, while a significantly reduced RPM allows the pump to deliver fewer strokes and extend consumable life.

SPECIFICATIONS

Output Flow	460 GPM
Maximum Pressure	3,000 PSI
Maximum RPM	300 RPM
Number of Plungers	3
Stroke Length	5" (12.7cm)
Weight without GB	3,937 lb (1,786 kg)
Break Horsepower (BHP)	250
Rod Load	50,000 lb (22,600 kg)
Dimensions without GB	67.3"L x 45.38"W x 29"H
Dimensions with GB	67.3"L x 54.38"W x 29"H

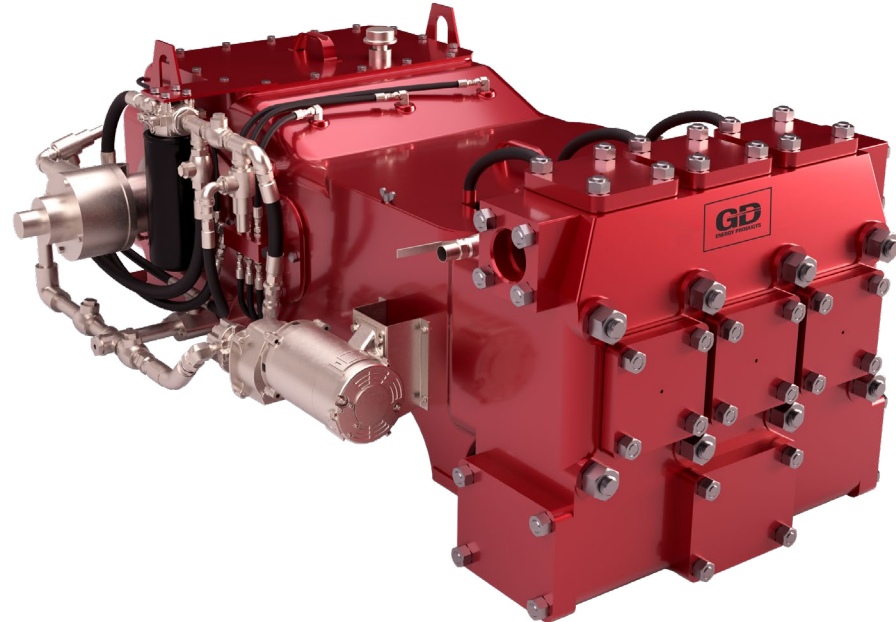

PISTON/LINEAR DIAMETER		DISPLACEMENT PER REVOLUTION		DISPLACEMENT AT PUMP RPM							
in.	mm.	Gallons	Liters	50				100			
				Pressure (PSI)	Pressure (kg/sq cm)	Flow (GPM)	Flow (LPM)	Pressure (PSI)	Pressure (kg/sq cm)	Flow (GPM)	Flow (LPM)
4	102	0.816	3.089	2944	207	41	153	2944	207	81	307
4.5	114	1.032	3.907	2944	207	51	194	2944	207	103	388
5	127	1.274	4.824	2944	207	63	240	2944	207	127	479
5.5	140	1.542	5.837	2944	207	77	290	2799	197	153	580
INPUT POWER		BHP		131				250			
		kW		98				186			

PISTON/LINEAR DIAMETER		DISPLACEMENT PER REVOLUTION		DISPLACEMENT AT PUMP RPM							
in.	mm.	Gallons	Liters	200				300			
				Pressure (PSI)	Pressure (kg/sq cm)	Flow (GPM)	Flow (LPM)	Pressure (PSI)	Pressure (kg/sq cm)	Flow (GPM)	Flow (LPM)
4	102	0.816	3.089	2714	191	158	598	1764	124	243	920
4.5	114	1.032	3.907	2091	147	205	776	1394	98	308	1164
5	127	1.274	4.824	1694	119	253	958	1129	79	380	1437
5.5	140	1.542	5.837	1400	98	306	1160	933	66	459	1739
INPUT POWER		BHP		250				250			
		kW		186				186			

A lubrication system supplying oil at 50 psi, 12 gpm and 200 SUS (44cSt) minimum values is required. Oil cooling recommended and may be required to maintain these values.

Performance figures based on 100% volumetric efficiency and 90% mechanical efficiency. These figures are for use in directional drilling duty cycle.

*This equals full rod load 33% of the time, 60% rod load 50% of the time and 25% rod load 17% of the time, for a total of 1456 hours per year.

GD 250HDD

HORIZONTAL DIRECTIONAL DRILLING PUMP

SPECIFICATIONS

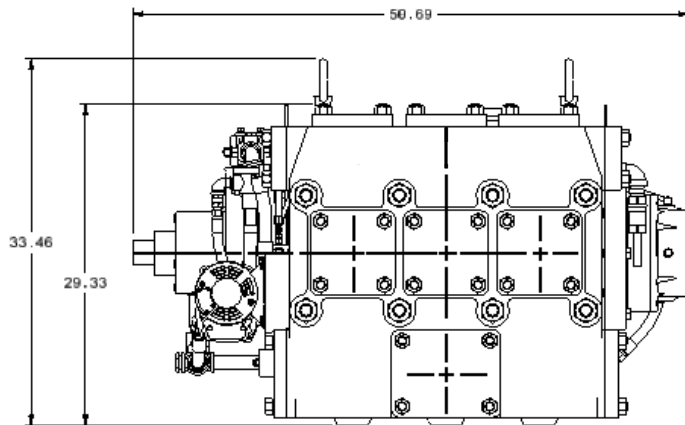
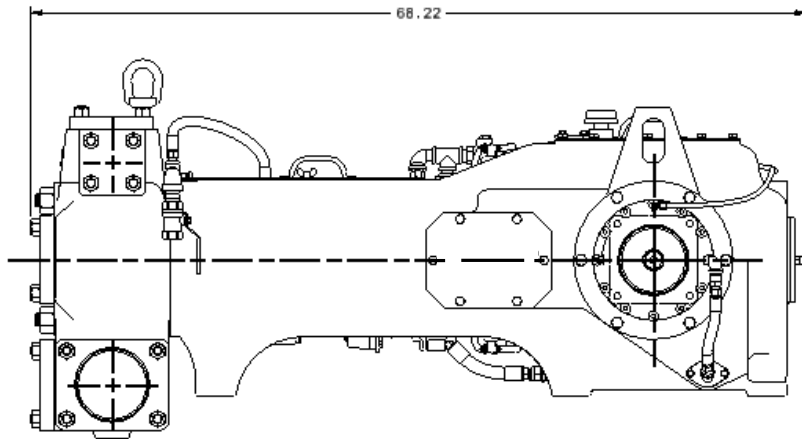

STANDARD FEATURES

- Featuring GD Energy Products' industry leading Redline Consumables for extended maintenance intervals
- Full cast ductile iron frame fluid end offers superior strength
- Large valve cover access panels for easy valve change outs
- All parts 100% made in the USA, guaranteeing build quality and reliability in the field
- Upgraded internal components and seal housing prevent contamination
- Coated crankshaft bearings to extend power end life
- Next generation fluid end technology with innovative geometry to minimize stress
- Left or right side suction and discharge connections
- Left or right handed keyed shaft extension
- Pressure lubricated power end (via engine driven oil pump - not supplied)
- Clamp style connections between piston rod and crosshead extensions
- Rod wash spray bar and baffles
- Multiple Drive Options:
 - Hydraulic Drive
 - Teardrop Spur Gearbox
 - Planetary Gearbox